



### FEATURES:

- 8 plungers, 64 sprays
- Solid brass construction
- Spray adjusting handle
- ½ in. NPT inlet
- Lexan deposit resisting plungers
- 2.5 gpm (9.5 L/min) flow rate

### COMPLIANCE:

- ASME A112.18.1/CSA B125.1 certified

### FINISH:

ADD SUFFIX TO MODEL #

- Polished Chrome (standard)
- Polished Brass  -PB
- Oil rubbed Bronze  -ORB
- Polished Nickel  -PN
- Brushed Nickel  -BN

### WARRANTY:

- Limited Lifetime Warranty (consumer use)
- 1 Year Limited (commercial use)

SEE REVERSE FOR ROUGH-IN DIMENSIONS

THIS SPACE FOR ARCHITECT/ENGINEER APPROVAL.

# SPEAKMAN®

400 ANCHOR MILL ROAD | NEW CASTLE, DE 19720  
P: 800-537-2107 | F: 800-977-2747  
WWW.SPEAKMANCOMPANY.COM

REVISION DATE: DECEMBER 2014



Management Systems  
Registered to ISO 9001

# SPEAKMAN®

## Icon™ Showerhead S-2251

SPECIFICATION

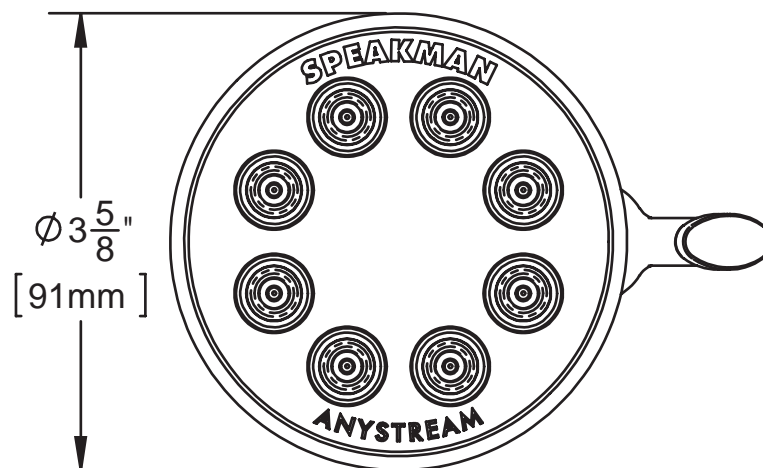
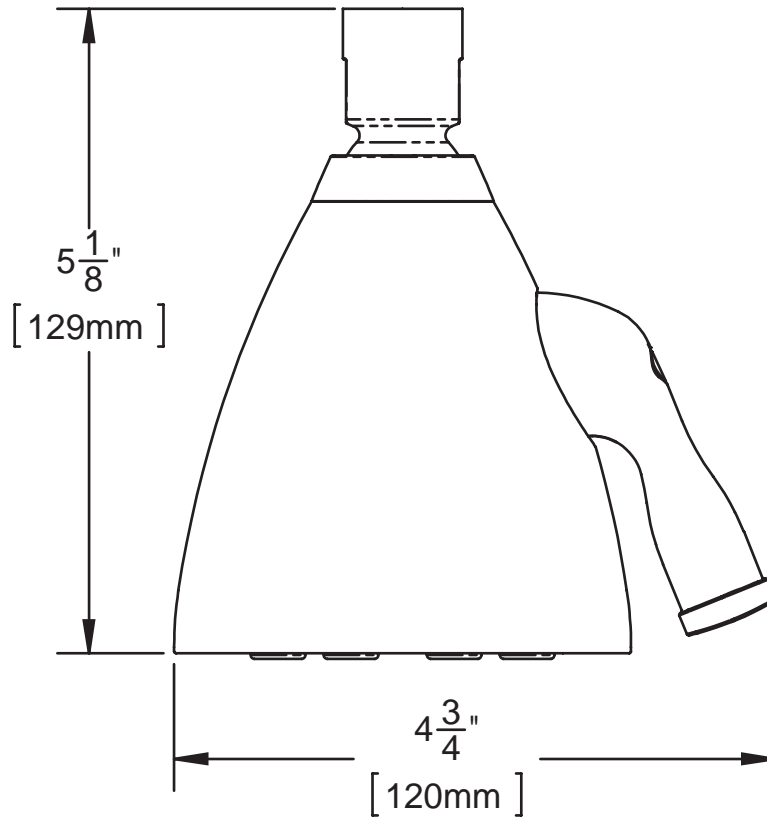

NOTE: 1. All dimensions are in inches (millimeters) unless otherwise specified and are subject to change without notice.

THIS SPACE FOR ARCHITECT/ENGINEER APPROVAL.

# SPEAKMAN®

400 ANCHOR MILL ROAD | NEW CASTLE, DE 19720  
P: 800-537-2107 | F: 800-977-2747  
WWW.SPEAKMANCOMPANY.COM



Management Systems  
Registered to ISO 9001

REVISION DATE: DECEMBER 2014