



FEATURES:

- Signature brass style
- 6 plungers, 48 sprays
- Solid brass construction
- Spray adjusting handle
- 2¾ in. diameter face
- ½ in. NPT inlet
- Lexan deposit resisting plungers
- 2.5 gpm (9.5 L/min) flow rate

COMPLIANCE:

- ASME A112.18.1/CSA B125.1 certified
- WaterSense certified (E2)



FINISHES:

ADD SUFFIX TO MODEL #

- Polished Chrome (standard)
- Brushed Nickel -BN
- Oil Rubbed Bronze -ORB
- Polished Brass -PB
- Polished Nickel -PN

OPTIONS:

ADD SUFFIX TO MODEL #

- 2.0 gpm flow rate -E2
- ½ in. British pipe thread inlet -BPT

WARRANTY:

- Limited Lifetime Warranty (consumer use)
- 1 Year Limited (commercial use)

SEE REVERSE FOR ROUGH-IN DIMENSIONS

THIS SPACE FOR ARCHITECT/ENGINEER APPROVAL.

SPEAKMAN®

400 ANCHOR MILL ROAD | NEW CASTLE, DE 19720
P: 800-537-2107 | F: 800-977-2747
WWW.SPEAKMANCOMPANY.COM

REVISION DATE: DECEMBER 2014



Management Systems
Registered to ISO 9001

SPEAKMAN®

Icon™ Showerhead S-2252

SPECIFICATION

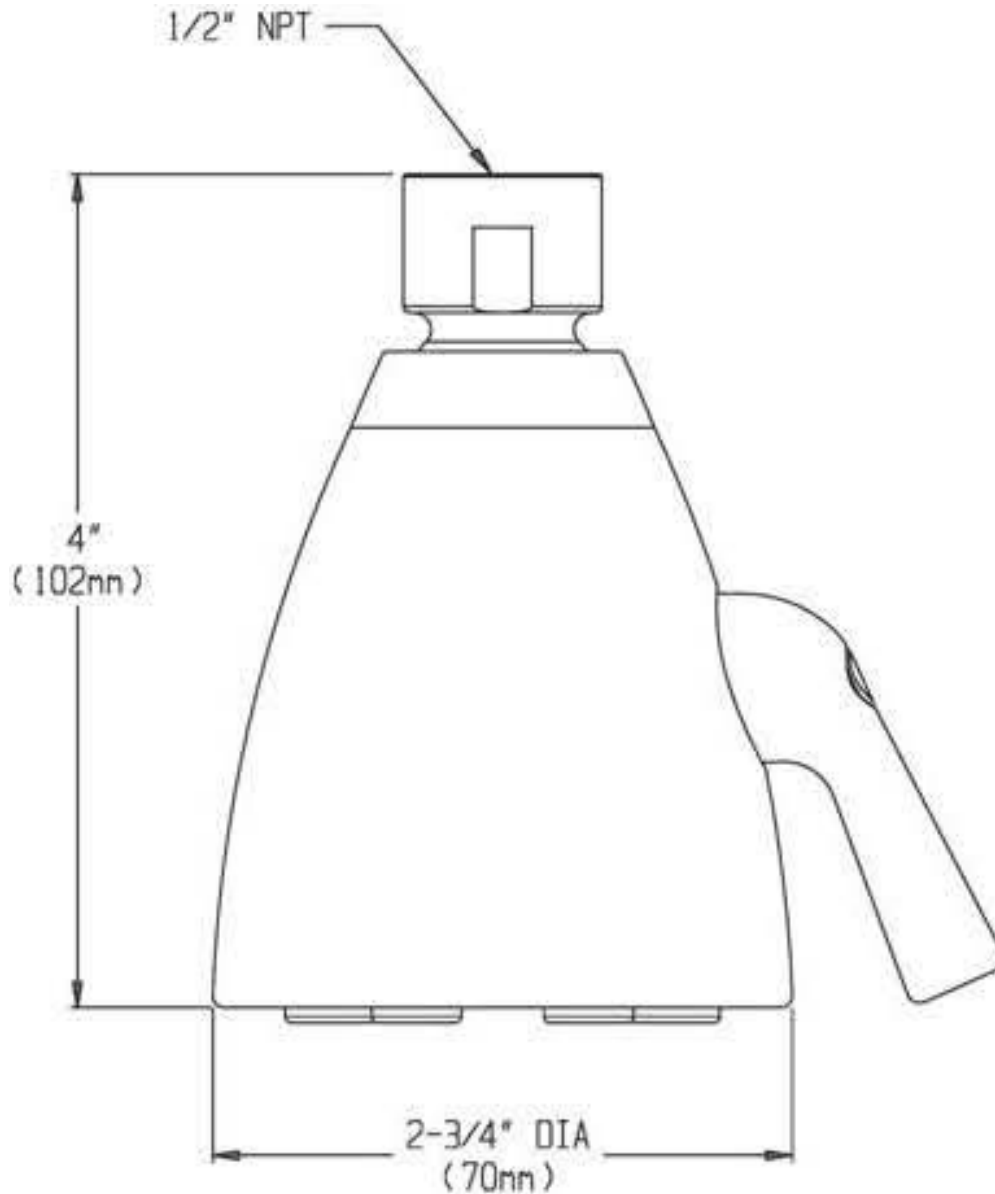

NOTE: 1. All dimensions are in inches (millimeters) unless otherwise specified and are subject to change without notice.

THIS SPACE FOR ARCHITECT/ENGINEER APPROVAL.

SPEAKMAN®

400 ANCHOR MILL ROAD | NEW CASTLE, DE 19720
P: 800-537-2107 | F: 800-977-2747
WWW.SPEAKMANCOMPANY.COM



Management Systems
Registered to ISO 9001

REVISION DATE: DECEMBER 2014