

Installation Instructions

for use by heating contractor

VIESSMANN®

Vitocrossal 200

CM2 Series 186, 246 and 311

Gas condensing boiler with cylinder burner

Heating input: 663 to 1112 MBH
194 to 326 kW



VITOCROSSAL 200



Product may not be exactly as shown

IMPORTANT

Read and save these instructions for future reference.

Safety, Installation and Warranty Requirements

Please ensure that these instructions are read and understood before commencing installation. Failure to comply with the instructions listed below and details printed in this manual can cause product/property damage, severe personal injury, and/or loss of life. Ensure all requirements below are understood and fulfilled (including detailed information found in manual subsections).

■ **Product documentation**

Read all applicable documentation before commencing installation. Store documentation near boiler in a readily accessible location for reference in the future by service personnel.

► *For a listing of applicable literature, please see section entitled "Important Regulatory and Safety Requirements".*



■ **Warranty**

Information contained in this and related product documentation must be read and followed. Failure to do so renders the warranty null and void.



■ **Licensed professional heating contractor**

The installation, adjustment, service and maintenance of this equipment must be performed by a licensed professional heating contractor.

► *Please see section entitled "Important Regulatory and Installation Requirements".*



■ **Contaminated air**

Air contaminated by chemicals can cause by-products in the combustion process, which are poisonous to inhabitants and destructive to Viessmann equipment.

► *For a listing of chemicals which cannot be stored in or near the boiler room, please see section entitled "Mechanical Room" in this manual.*



■ **Advice to owner**

Once the installation work is complete, the heating contractor must familiarize the system operator/ultimate owner with all equipment, as well as safety precautions/requirements, shutdown procedure, and the need for professional service annually before the heating season begins.

■ **Carbon monoxide**

Improper installation, adjustment, service and/or maintenance can cause flue products to flow into living space. Flue products contain poisonous carbon monoxide gas.

► *For information pertaining to the proper installation, adjustment, service and maintenance of this equipment to avoid formation of carbon monoxide, please see section entitled "Combustion air supply" and "Venting information" in this manual.*



■ **Fresh air**

This equipment requires fresh air for safe operation and must be installed ensuring provisions for adequate combustion and ventilation air exist.

► *For information pertaining to the fresh air requirements of this product, please see subsection entitled "Mechanical Room" in this manual.*

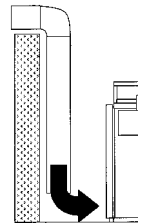

■ **Equipment venting**

Never operate boiler without an installed venting system. An improper venting system can cause carbon monoxide poisoning.

► *For information pertaining to venting and chimney requirements, please see section entitled "Venting Information" in this manual. All products of combustion must be safely vented to the outdoors.*



! WARNING

Installers must follow local regulations with respect to installation of carbon monoxide detectors. Follow the Viessmann maintenance schedule of the boiler in the "Service Instructions" manual.

Introduction

Safety, Installation and Warranty Requirements.....2
 Product documentation.....2
 Warranty.....2
 Licensed professional heating contractor.....2
 Contaminated air.....2
 Advice to owner.....2
 Carbon monoxide.....2
 Fresh air.....2
 Equipment venting.....2

Safety

Important Regulatory and Installation Requirements.....5
 Fiberglass wool and ceramic fiber material.....5
 First aid measures.....5
 Codes.....5
 Mechanical room.....5
 For installations on the Commonwealth of
 Massachusetts.....6
 For polypropylene venting systems only.....7
 Venting clearance to combustibles
 (Stainless Steel / Polypropylene).....7
 Working on the equipment.....8
 Technical literature.....8

General Information

About these Installation Instructions.....8
Product Information.....9
Mechanical Room.....9
For Retrofit Applications.....9

Boiler

Recommended Minimum Service Clearances10
Preparing the Boiler.....11
Flex Hose Air Intake Adaptor.....11
Boiler Insulation.....12
Boiler Connections.....12
 Water side connection.....12
 Safety Header.....13
Hydrostatic Test Procedure.....14
Burner Installation.....15
Burner Hinge Reinstallation (if required).....15
Rails and Front Panels.....16
Combustion Air Flex Hose.....16
Combustion Air Adapter Burner Connection.....17
Side Panels.....18
Side Panels (front).....18
Flue Gas Temperature Switch.....19
Installing the Flue Gas Temperature Switch.....19
Wiring the Flue Gas Temperature Switch.....19
Rear Panels.....20
Boiler Control and Junction Box.....20
Gas Flue Temperature Switch Connection.....21
Sensors and Buffer Panel.....21
Top Panels.....22
Gas Flue Connections.....22
Condensate Connection.....23
Gas Connections.....24
 Gas valve flange installation.....24
 Valve leak test.....25
Burner Electrical Connections.....26
Front Panel (door).....27
Boiler Piping in Heating / Cooling Application.....27
Initial System Fill.....28

Venting

General Venting Information.....29
 Installation steps (outline).....29
Recommended Venting Practice.....29
 Approved venting materials.....30
 Vent termination location requirements
 (for installations in Canada).....31
 Vent termination location requirements
 (for installations in the U.S.A.).....31
 Flashing and storm collar installation.....32
Additional Requirements for Stainless Steel
Vent Pipe Material.....32
 Exhaust vent/air intake connection to boiler.....32
Requirement for UL/ULC listed Rigid PP
Vent Pipe Material.....33
 Requirements for PP and stainless steel.....33
 Vent system suppliers.....33
Vent Requirements.....34
 Combustion air supply, room air dependant
 application only.....34
Direct Venting (Two Pipe System).....35
 Side wall vent termination [stainless steel, CPVC or PP]...35
Side Wall Venting.....36
 Side wall vent termination [stainless steel or PP].....36
Component Installation Guide.....37
 Flashing and storm collar installation.....37
Vent Termination Location Requirements - Vertical.....37
Installation of Support System - PP.....38
 Bracing.....38
 Vent System Suppliers.....38
Long Sweep Elbows.....38
 Standard long sweep elbow equivalent length material...38

Venting Options - Stainless Steel/PP

Two Pipe System-Vertical Exhaust/Vertical Air Intake....39
Two Pipe System-Horizontal Exhaust/Horizontal Air Intake....41
Two Pipe System-Vertical Exhaust/Horizontal Air Intake..42
Two Pipe System-Vertical/Horizontal Installations.....42
Single Pipe System-Vertical Exhaust /
Room Air Dependent.....43
Single Pipe System-Horizontal Exhaust /
Room Air Dependent.....43
Single Pipe System-Vertical/Horizontal Installations.....44
 Maximum allowable equivalent length -
 stainless steel / PP.....44
Multiple Boiler Installations.....44
 Horizontal vent termination.....44
 Vertical vent termination.....44
Two Pipe System-Vertical Exhaust/Vertical Air Intake....45
Two Pipe System-Horizontal Exhaust/Horizontal Air Intake....46
Two Pipe System-Vertical Exhaust/Horizontal Air Intake..47
Single Pipe-Vertical Exhaust / Room Air Dependent.....48
Single Pipe-Horizontal Exhaust / Room Air Dependent.....49

Important Regulatory and Installation Requirements *(continued)*

Fiberglass wool and ceramic fiber materials

WARNING

Inhaling of fiberglass wool and/or ceramic fiber materials is a possible cancer hazard. These materials can also cause respiratory, skin and eye irritation.

The state of California has listed the airborne fibers of these materials as a possible cancer hazard through inhalation. When handling these materials, special care must be applied.

Suppliers of ceramic fiber products recommend the following first aid measures:

- *Respiratory tract (nose and throat) irritation:*
If respiratory tract irritation develops, move the person to a dust free location.
- *Eye irritation:* If eyes become irritated, flush immediately with large amounts of lukewarm water for at least 15 minutes. Eyelids should be held away from the eyeball to ensure thorough rinsing. Do not rub eyes.
- *Skin irritation:* If skin becomes irritated, remove soiled clothing. Do not rub or scratch exposed skin. Wash area of contact thoroughly with soap and water. Using a skin cream or lotion after washing may be helpful.
- *Gastrointestinal irritation:* If gastrointestinal tract irritation develops, move the person to a dust free environment.

Suppliers of fiberglass wool products recommend the following precautions be taken when handling these materials:

- Avoid breathing fiberglass dust and contact with skin and eyes.
- Use NIOSH approved dust/mist respirator.
- Wear long-sleeved, loose fitting clothing, gloves and eye protection.
- Wash work clothes separately from other clothing. Rinse washer thoroughly.
- Operations such as sawing, blowing, tear-out and spraying may generate airborne fiber concentration requiring additional protection.

First aid measures

- If eye contact occurs, flush eyes with water to remove dust. If symptoms persist, seek medical attention.
- If skin contact occurs, wash affected areas gently with soap and warm water after handling.

WARNING

Appliance materials of construction, products of combustion and the fuel contain alumina, silica, heavy metals, carbon monoxide, nitrogen oxides, aldehydes and/or other toxic or harmful substances which can cause serious injury or loss of life and which are known to the State of California to cause cancer, birth defects and other reproductive harm. Always use proper safety clothing, respirators and equipment when servicing or working nearby the appliance.

Codes

The installation of this unit shall be in accordance with local codes. In the absence of local codes, use:

CAN/CSA-B149.1 or .2 Installation Codes for Gas Burning Appliances for Canada. For U.S. installations, use the National Fuel Gas Code ANSI Z223.1. Always use latest editions of codes.

In Canada all electrical wiring is to be done in accordance with the latest edition of CSA C22.1 Part 1 and/or local codes. In the U.S., use the National Electrical Code ANSI/NFPA 70.

The heating contractor must also comply with the Standard for Controls and Safety Devices for Automatically Fired Boilers, ANSI/ASME CSD-1 where required by the authority having jurisdiction.

Mechanical room

Ensure the mechanical room complies with the requirements of the System Design Guidelines and/or Technical Data Manual.

In addition, see section entitled "Mechanical Room" on page 9 in this manual.

Viessmann recommends installation of an additional electrical disconnect switch and a fuel shut-off valve (if possible) outside the mechanical room or enclosed area of installation.

The maximum room temperature of the mechanical room where the boiler is located must not exceed 104°F (40°C).

Important Regulatory and Installation Requirements *(continued)*

For installations on the Commonwealth of Massachusetts, the following modifications to NFPA-54 chapter 10 apply:

Excerpt from 248 CMR 5-08:

- 2(a) For all side-wall horizontally vented gas fueled equipment installed in every dwelling, building or structure used in whole or in part for residential purposes, including those owned or operated by the Commonwealth and where the side-wall exhaust vent termination is less than (7) feet above finished grade in the area of the venting, including but not limited to decks and porches, the following requirements shall be satisfied:
1. **INSTALLATION OF CARBON MONOXIDE DETECTORS.** At the time of installation of the side-wall horizontal vented gas fueled equipment, the installing plumber or gas fitter shall observe that a hard wired carbon monoxide detector with an alarm and battery back-up is installed on the floor level where the gas equipment is to be installed. In addition, the installing plumber or gas fitter shall observe that a battery operated or hard wired carbon monoxide detector with an alarm is installed on each additional level of the dwelling, building or structure served by the side-wall horizontal vented gas fueled equipment. It shall be the responsibility of the property owner to secure the services of qualified licensed professional for the installation of hard-wired carbon monoxide detectors.
 - a. In the event that the side-wall horizontally vented gas fueled equipment is installed in a crawl space or an attic, the hard-wired carbon monoxide detector with alarm and battery back-up may be installed on the next adjacent floor level.
 - b. In the event that the requirements of this subdivision can not be met at the time of completion of installation, the owner shall have a period of thirty (30) days to comply with the above requirements; provided, however, that during said thirty (30) day period, a battery operated carbon monoxide detector with an alarm shall be installed.
 2. **APPROVED CARBON MONOXIDE DETECTORS.** Each carbon monoxide detector as required in accordance with the above provisions shall comply with NFPA 720 and be ANSI/UL 2034 listed and IAS certified.
 3. **SIGNAGE.** A metal or plastic identification plate shall be permanently mounted to the exterior of the building at a minimum height of eight (8) feet above grade directly in line with the exhaust vent terminal for the horizontally vented gas fueled heating appliance or equipment. The sign shall read, in print size no less than one-half (1/2) inch in size, "GAS VENT DIRECTLY BELOW. KEEP CLEAR OF ALL OBSTRUCTIONS".
 4. **INSPECTION.** The state or local gas inspector of the side-wall horizontally vented gas fueled equipment shall not approve the installation unless, upon inspection, the inspector observes carbon monoxide detectors and signage installed in accordance with the provisions of 248 CMR 5.08(2)(a) 1 through 4.
- (b) **EXEMPTIONS:** The following equipment is exempt from 248 CMR 5.08(2)(a) 1 through 4:
1. The equipment listed in Chapter 10 entitled "Equipment Not Required To Be Vented" in the most current edition of NFPA 54 as adopted by the Board; and
 2. Product Approved side-wall horizontally vented gas fueled equipment installed in a room or structure separate from the dwelling, building or structure used in whole or in part for residential purposes.

Important Regulatory and Installation Requirements *(continued)***For Polypropylene venting systems only**

Minimum and maximum wall thickness through which the horizontal vent-air intake termination may be installed:

Minimum: 1 in. (25.4 mm)

Maximum: 30 in. (762 mm)

Vent-air intake system must be properly installed and sealed.

If PP venting system passes through an unheated space, such as an attic, it must be insulated.

The insulation must have an R value sufficient to prevent freezing of the condensate. Armaflex insulation with ½ in. thickness and higher can be used.

Venting clearance to combustibles (Stainless Steel / Polypropylene)

As per vent manufacturer's requirements.

 **WARNING**

The Vitocrossal 200 is **NOT** approved for common venting applications.
Do not attempt to common-vent the boiler with any other appliance.

 **WARNING**

Failure to ensure that all flue gases have been safely vented to the outdoors can cause property damage, severe personal injury, or loss of life. Flue gases may contain deadly carbon monoxide.

 **CAUTION**

Under certain climatic conditions some building materials may be affected by flue products expelled in close proximity to unprotected surfaces. Sealing or shielding of the exposed surfaces with a corrosion resistant material (e.g. aluminum sheeting) may be required to prevent staining or deterioration. The protective material should be attached and sealed (if necessary) to the building before attaching the vent termination. It is strongly recommended to install the vent termination on the leeward side of the building.

Important Regulatory and Installation Requirements *(continued)*

Working on the equipment

The installation, adjustment, service, and maintenance of this boiler must be performed by a licensed professional heating contractor who is qualified and experienced in the installation, service, and maintenance of hot water boilers. There are no user serviceable parts on the boiler, burners, or control.

Ensure main power supply to equipment, the heating system, and all external controls has been deactivated. Close main gas supply valve. Take precautions in all instances to avoid accidental activation of power during service work.

Technical literature

Literature for the Vitocrossal 200 CM2 boiler:

- Technical Data Manual
- Installation Instructions
- Service Instructions
- Operating Instruction
- Instructions of other products utilized and installed
- Installation codes mentioned in this manual and as locally applicable

► *The completeness and functionality of field supplied electrical controls and components must be verified by the heating contractor. This includes low water cut-offs, flow switches (if used), staging controls, pumps, motorized valves, air vents, thermostats, etc.*

► *Leave all literature at the installation site and advise the system operator/ultimate owner where the literature can be found. Contact Viessmann for additional copies.*

► *This product comes with several safety instruction labels attached. Do not remove! Contact Viessmann immediately if replacement labels are required.*

About these Installation Instructions

 Take note of all symbols and notations intended to draw attention to potential hazards or important product information. These include "WARNING", "CAUTION", and "IMPORTANT". See below.

 **WARNING**

Indicates an imminently hazardous situation which, if not avoided, could result in death, serious injury or substantial product/property damage.

► *Warnings draw your attention to the presence of potential hazards or important product information.*

 **CAUTION**

Indicates an imminently hazardous situation which, if not avoided, may result in minor injury or product/property damage.

► *Cautions draw your attention to the presence of potential hazards or important product information.*

IMPORTANT

► *Helpful hints for installation, operation or maintenance which pertain to the product.*



► *This symbol indicates that additional, pertinent information is to be found.*



► *This symbol indicates that other instructions must be referenced.*

Product Information

High efficiency gas-fired hot water condensing boiler.

For operation with modulating boiler water temperatures in closed loop, forced circulation hot water heating systems.

The Vitocrossal 200, CM2 boilers are CSA certified with Viessmann burners which must be used in conjunction with this boiler series.

The proper burner size must be verified and the burner must be adjusted so that the maximum input of the appropriate boiler size is always observed and adjusted. The gas burner must always be installed according to the instructions provided by the burner manufacturer.

The boiler model selected should be based on an accurate heat loss calculation of the building. The boiler selected must be compatible with the connected radiation.

The Vitocrossal 200 boiler is suitable for a maximum operating pressure of 75 psig and a maximum boiler water temperature of 210°F (99°C).

This boiler does not require a flow switch.



WARNING

Exposing the boiler to pressures and temperatures in excess of those listed will result in damages, and will render warranty null and void.

Mechanical Room

The Vitocrossal 200, CM2 boiler should be located in a heated indoor space. The boiler should also be located near a floor drain and as close as possible to the vertical chimney or vent.

Whenever possible, install boiler near an outside wall so that it is easy to duct fresh air directly to the boiler area.

Install boiler on flooring capable of supporting the weight of the boiler filled with water.

Do not use exhaust fans without adding additional provisions for fresh combustion air (e.g. fresh air fan) in the boiler room and do not install the Vitocrossal 200 boiler in rooms with refrigeration equipment. This boiler requires uncontaminated air for safe operation - do not install where chemicals are stored.

- Do not operate when air is polluted with halogenated hydrocarbons (e.g. as in aerosols, paints, solvents and cleaning agents)
- Prevent very dusty conditions
- Prevent high levels of humidity
- Prevent freezing and ensure good ventilation.

Otherwise, the system may suffer faults and damage.

For Retrofit Applications

Before boiler is connected to piping/heating system, (which have been previously in service) the piping must be flushed with city pressure water (50-60 psi) to remove sludge and other contaminates.

Failure to flush out the heating system piping may result in restricted flow and/or deposits resulting in boiler failure. This failure is not covered under warranty.

Recommended Minimum Service Clearances

To enable convenient installation and maintenance, observe the stated clearance dimensions. Maintain the minimum clearances where space is tight.

In the delivered condition, the boiler door hinge bracket is factory installed on the left side of the door. If required, the boiler door hinge bracket can be reinstalled on the right side of the door. See burner hinge reinstallation on page 15.

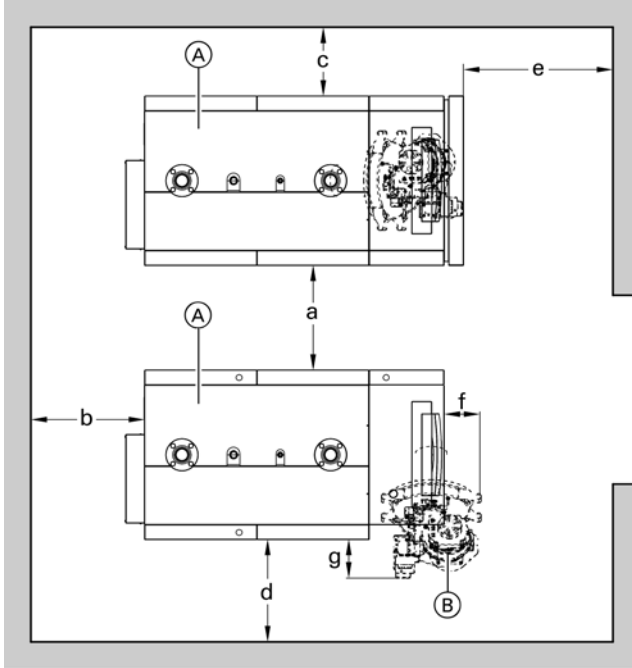

CM2	186	246	311
a *1 in. (mm)	20 (500)	20 (500)	20 (500)
b *2 in. (mm)	30 (760)	30 (760)	30 (760)
c in. (mm)	20 (500)	20 (500)	20 (500)
d in. (mm)	20 (500)	20 (500)	20 (500)
e in. (mm)	24 (600)	24 (600)	24 (600)
f in. (mm)	22 (550)	22 (550)	22 (55)
g in. (mm)	15½ (395)	15½ (395)	15½ (395)

*1 Clearance may be reduced to zero in multi-boiler installations, provided the side panel removal is not required.

Note: The burner, boiler control, condensate trap, venting and heat exchanger are still fully accessible from the front and rear of the boiler.

*2 Clearance for vent pipe installation.

Legend

- (A) Boiler
- (B) Burner

Minimum clearances to combustibles

Boiler model CM2	186	246	311
Top	0		
Sides	0		
Flue	As per vent manufacturer's specifications		
Front	0		
Floor	combustible		

Preparing the Boiler

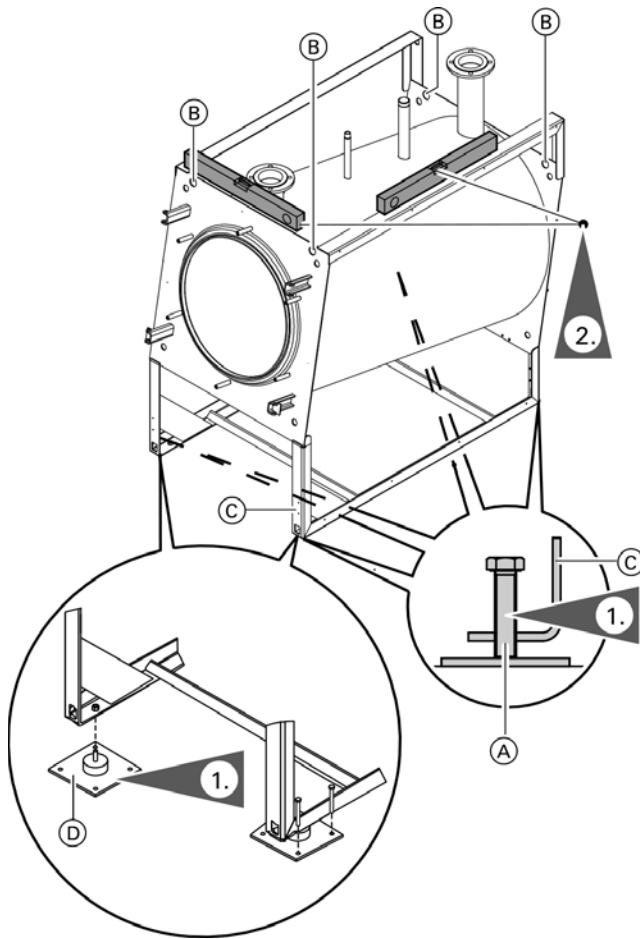

Legend

- (A) Leveling bolt
- (B) Boiler end plates (lifting holes)
- (C) Boiler frame
- (D) Seismic mount (optional accessory)

Note: To install cargo gear, use the gaps in the boiler frame (B).

Observe the minimum clearances, see page 10.

It is recommended that the boiler is to be installed on a concrete base.

A recommended size of the concrete boiler base should be 50 in. (1250 mm) wide x 31 in. (800 mm) long x 4" (100 mm) thick for each boiler.

WARNING

If flue gas connection is damaged leakage may occur. Do not lift boiler at the flue gas connection.

1. Remove the wooden shipping block from boiler base. Remove the 4 leveling bolts (A) from boiler's accessory package and install into boiler base.
Note: When using seismic mounts (optional accessory) do not install levelling bolts.



Refer to the Seismic bracket Installation Instructions when using the optional seismic mounts.

2. It is recommended to place a flat piece of steel plate under each leveling bolt for better weight distribution and adjustment. Level the boiler, by adjusting the floor leveling bolts.
3. Remove the wooden block on the boiler doors.

Note: If the boiler is installed even with the ground, install a condensing drain above the ground max. 2 in. (50 mm).

Flex Hose Air Intake Adaptor

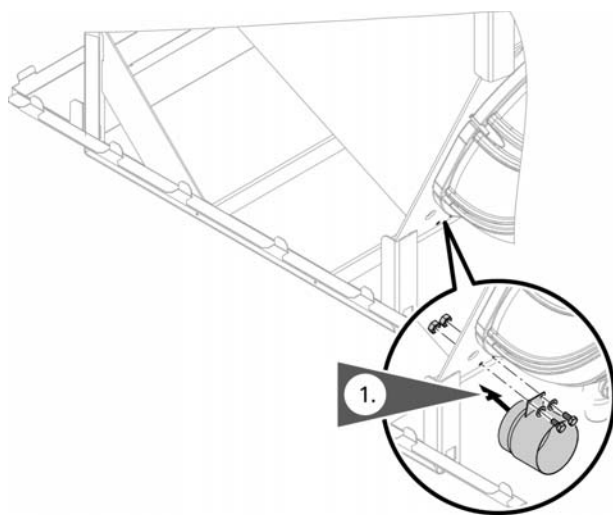

Note: The combustion air intake adaptor must be installed before installing the boiler insulation (whether the air for the combustion is drawn directly from the outdoors or a Room Air Dependent combustion system is used).

1. Attach the flex hose adaptor to the boiler frame using two M8 bolts, nuts and washers.

Boiler Insulation

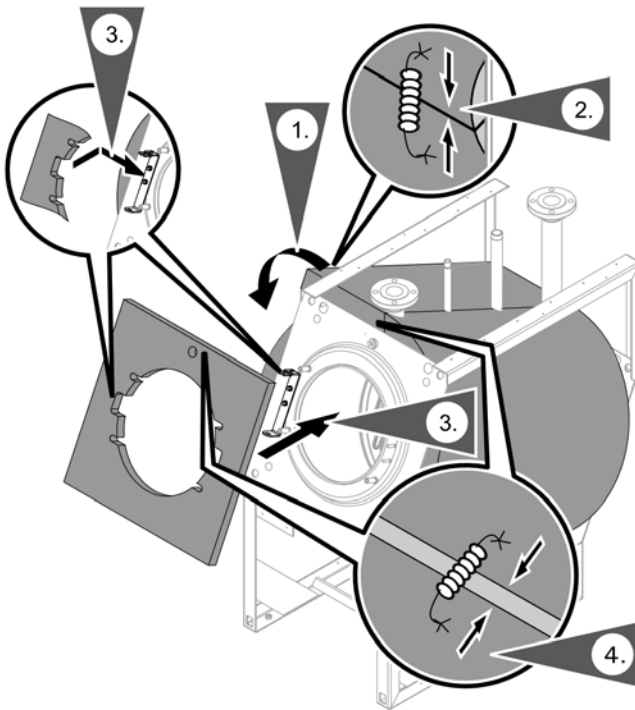

Remove all the components of the boiler jacket from the shipping box.

1. Wrap around the insulation blanket (black nylon facing out) and look for boiler's fitting cutouts.
2. Secure the ends of the blankets with supplied springs.
3. Mount front insulation blanket (If necessary change the burner door bracket to right hand opening, see page 15 for details). Secure with springs.
4. Secure the front insulation blanket with supplied springs.

Boiler Connections

Water Side Connection

Note: Make all connections free of load and torque stresses.

The existing heating system must be properly flushed, especially if the Vitocrossal 200 boiler is connected to an existing heating system in a retrofit application. See page 9 for details.

Connect the system to the boiler according the diagram on page 13 and 14.

Note: All connections which are not being utilized for water connections or for controls must be properly closed.

The supplied air vent and pressure relief valve must be installed on the top of the boiler - the alternate pressure relief valve location may be in the boiler supply line. The piping to the precharged expansion tank, as well as any automatic feed water required, must be connected to the boiler drain opening or the safety return connection.

Boiler pump shall be installed on return pipe, pumping water into the boiler.

The supplied low water cut-off should be installed directly on top of the boiler or may be installed in the boiler return piping above the pressure vessel.

Note: Piping diagrams for specific system layouts are available. Please enquire with your local Viessmann sales representative.

IMPORTANT

The Vitocrossal 200 is only suited for hot water heating. Do not install a 4-way mixing valve, bypass valve or similar.

Boiler Connections *(continued)*

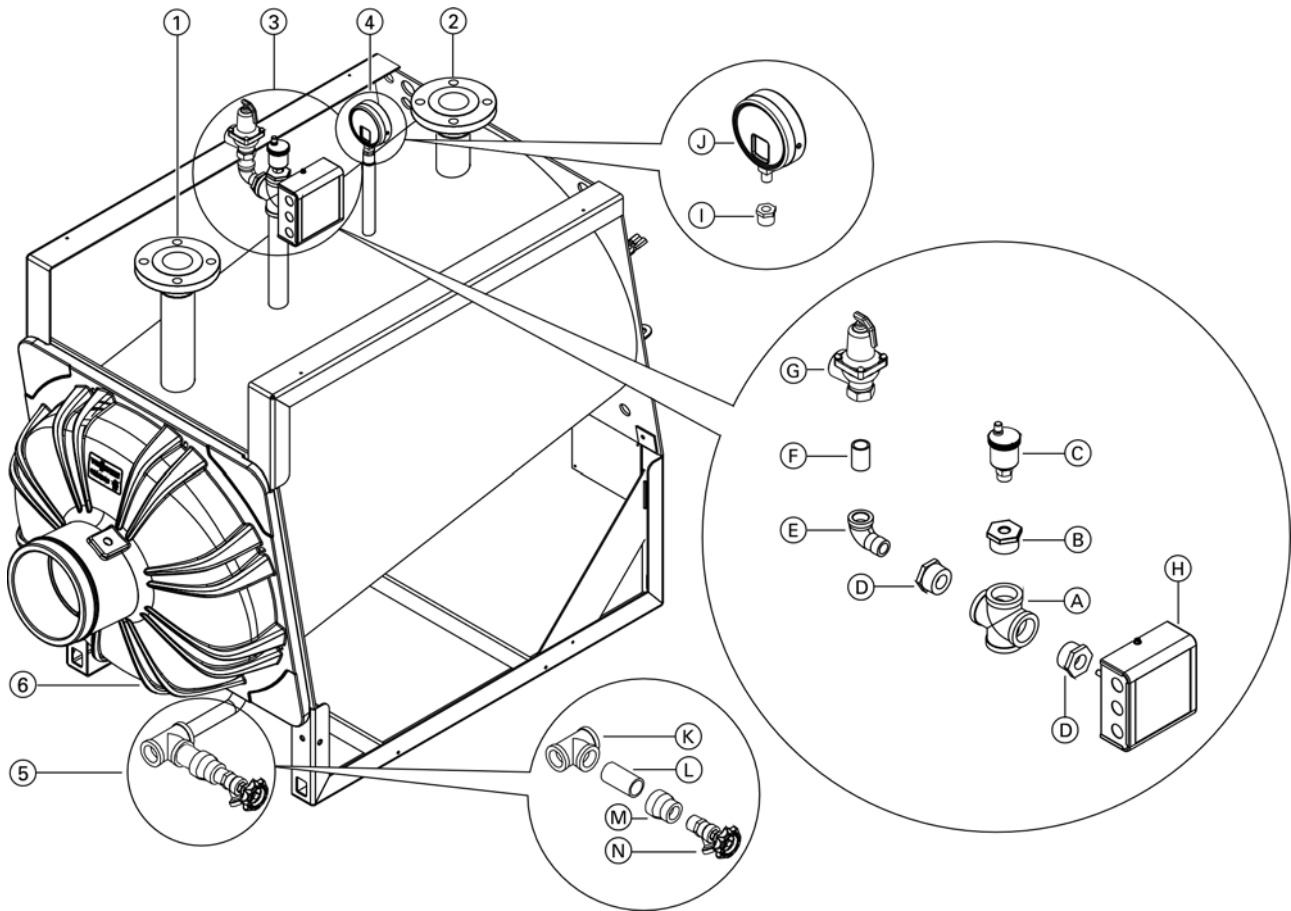

Legend

- ① Boiler return: (ANSI flanges 2½ in.) *1
- ② Boiler supply: (ANSI flanges 2½ in.)*1
- ③ Safety port (Safety valve, low water cutoff and automatic air vent) NPT 1¼
 - (A) Cross 1¼ in.
 - (B) Hex bushing 1¼ in. x ¾ in.
 - (C) Air vent with shut-off base
 - (D) Hex bushing 1¼ in. x ¾ in.
 - (E) 90° Street elbow ¾ in.
 - (F) Nipple ¾ in. x 1 ½ in.
 - (G) Pressure relief valve, 75 psi
 - (H) Low water cutoff
- ④ Air vent or pressure gauge fem. connection NPT ½ in.
 - (I) Hex bushing ½ in. x ¼ in.
 - (J) Pressure gauge
- ⑤ Drain and fitting for membrane expansion tank NPT 1
- ⑥ Condensing water drain ½ in. barb connector
 - (K) Tee
 - (L) Nipple 1 in. x 2 in.
 - (M) Reducer coupling 1 in. x ¾ in.
 - (N) Sediment faucet ¾ in.

Thermometer *2 *(not shown)*

Safety Header

CAUTION

Do not connect heating system to safety header.

1. Locate safety port on boiler.
2. Install safety header to safety port.

Water pressure: 75 psi (5.2 bar)
 Testing pressure: 112 psi (8.2 bar)
 Min. water pressure: 8 psi (0.5 bar)

Note: The minimum water pressure is necessary for safe operation.

Safety valve: All boilers must have a pressure relief valve.

Note: Make all connections free of load and torque stresses.

*1 Counter flanges ANSI 2½ in., gaskets and hardware (field supplied)

*2 Install anywhere in the supply piping near boiler *(not shown)*

Hydrostatic Test Procedure

All Vitocrossal boilers are factory tested (hydrostatic testing) to ASME requirements. The following testing procedure is to ensure that the boiler remained intact during shipping and handling.

1. Isolate boiler from hydronic heating system using isolating valves (i.e. expansion tank, feed water valve, pressure relief valve etc.).
2. Remove 75 psig pressure relief valve from the boiler and cap pipe outlet.
3. Fill boiler with city water and pressurize it to one and a half (1½) times the maximum working pressure of boiler. The pressure must be controlled such that it will never be 10 psig higher than the testing pressure.

Max. allowable working pressure: 75 psig

Testing pressure: 112 psig (do not exceed 122 psig)



WARNING

Never expose the boiler to any pressures higher than 122 psig during testing.

4. Monitor pressure over a period of approximately one hour to ensure that the pressure remains constant and steady at 112 psig.
5. Should there be a drop in pressure, ensure that all fittings are secure and tight. Check all flanged connections with a flashlight.
6. Flue gas collector shall be removed for boiler inspection should the test water show up in the condensate drain.
7. Open the boiler combustion chamber door and inspect with a flashlight the front portion of the Inox-Crossal® heat exchanger sections for system water or fluid.
8. If test is successful, reinstall all hydronic system components and refill the boiler with water or system fluid.

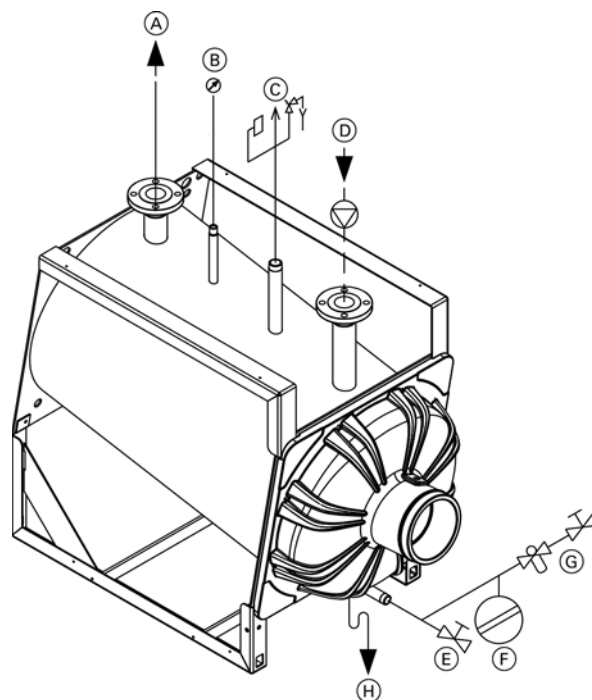

Legend

- (A) Boiler supply
- (B) Pressure gauge
- (C) Pressure relief valve
- (D) Boiler return
- (E) Drain valve
- (F) Precharged expansion tank
- (G) Automatic fill
- (H) Condensing water drain

Burner Installation

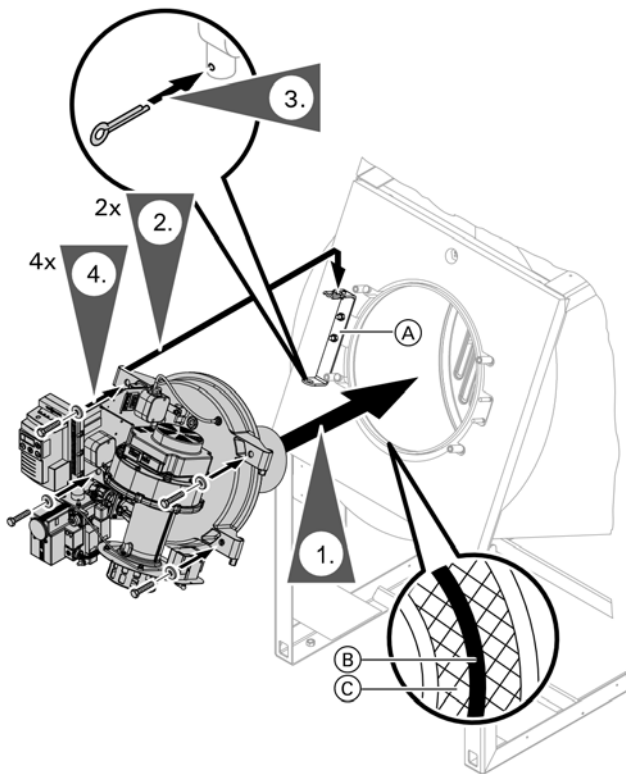

Legend

- (A) Burner hinge bracket
- (B) Sealing frame
- (C) Burner door seal

Note: If the burner hinge bracket (A) is reinstalled please note that sealing frame (B) has to press on center of burner door sealing (C).

1. Remove burner from shipping package and align with boiler opening.

Note: All parts needed for burner installation are included in the burner shipping package.

2. Hang the burner on the hinges bracket.

Note: The burner hinge bracket can be reinstalled on the other side of the door if required. Reinstall per instructions below.

3. Secure the hinges with cotter pins.

4. Tighten the burner body with four M12 bolts and torque to 13 lb/ft (18 Nm).

Note: If the four burner door bolts do not line up with the holes on the boiler, loosen the two nuts on hinge (A), align the burner door bolts and tighten again.

WARNING

Flue gas leakage may lead to property damage, severe personal injury, or loss of life. Flue gas may contain deadly carbon monoxide.

Note: For ease during burner maintenance, route the gas supply pipe from the opposite side of the burner hinges.

IMPORTANT

NPT gas valve connection flange is shipped loose in burner package.

Install the flange on inlet side of the gas combination valve. Use supplied O-ring and 4 mm Allen screws. Tighten with 1.5 lb/ft (2 Nm) torque.

Burner Hinge Reinstallation (if required)

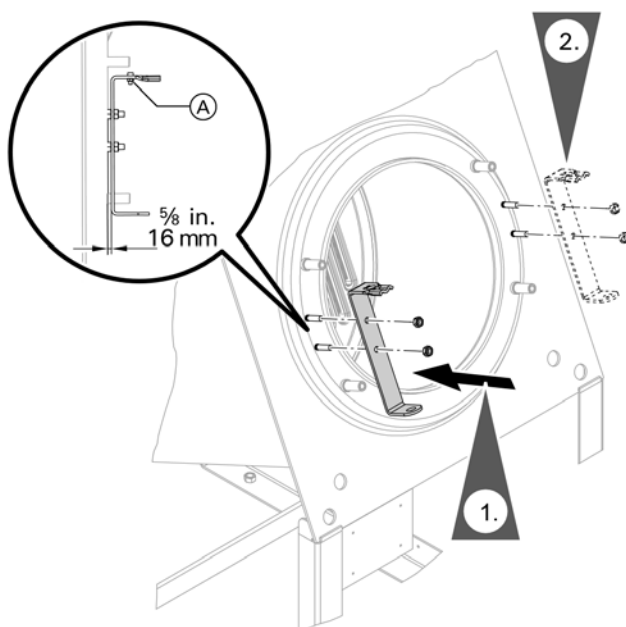

1. Loosen two nuts and remove burner door hinges.
2. Reinstall burner door hinges on the other side of the boiler. Ensure the stop screw (A) is at the top of the door hinge and relocated to the outside hole. Secure the door hinge with nuts and torque to 37 lb/ft (50 Nm).

Note: Gas line connection is made to the opposite side of bracket. See page 26 for details.

Note: If the burner hinge bracket is reinstalled note that sealing frame has to press on center of burner door sealing.

Rails and Front Panels

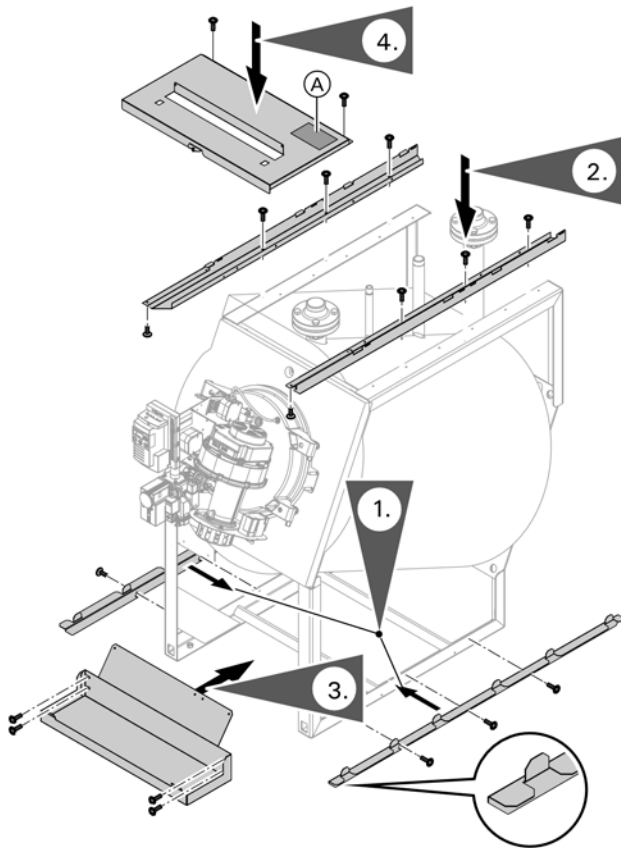

1. Install mounting rails to bottom of boiler frame using M6 x 10 screws.
2. Install mounting rails to top of boiler frame using M6 x 10 screws.
3. Install bottom panel to front of boiler frame using M6 screws. (Be careful not to move mounting rails).
4. Install front control panel (top) and secure with 4.8 metal screws.

Legend

- Ⓐ Rating Plate

Combustion Air Flex Hose

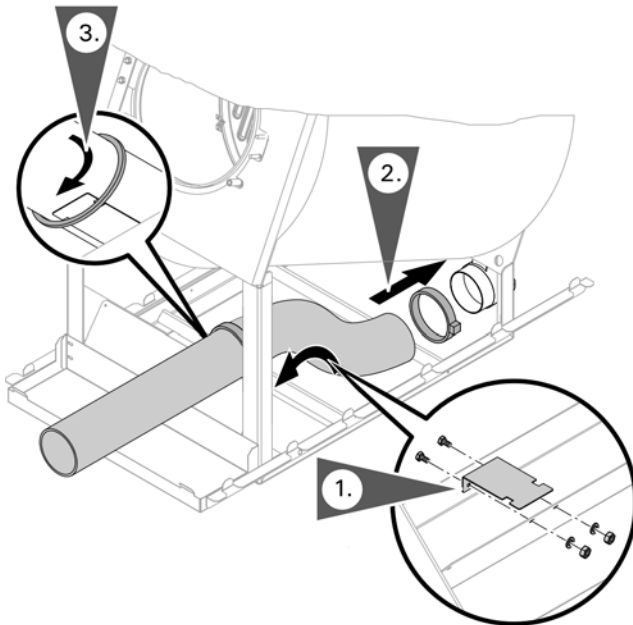

1. Install support bracket for flex hose to bottom panel using two M4 x 10 screws, nuts and washers.
2. Attach the flex hose \varnothing 6 in. (150 mm) to the flex hose adaptor and secure the flex hose to the flex hose adaptor with the retaining clamp.
3. Secure the flex hose to the support bracket with the retaining clamp.

Note: Do not squeeze hose when securing it with the retaining clamp.

Combustion Air Adaptor Burner Connection

For CM2 boiler model 186 only

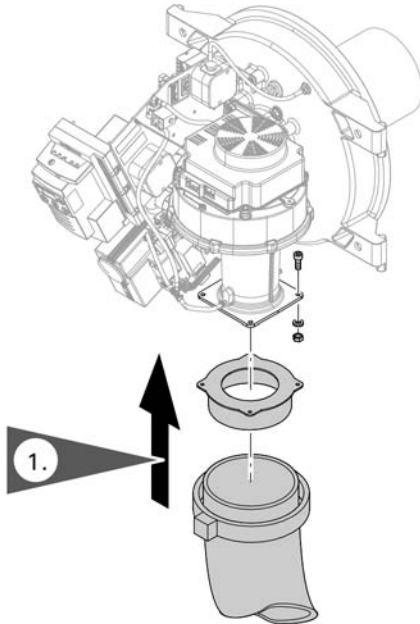

1. Install the combustion air intake adaptor to the burner air inlet using four M6 x 20 bolts, nuts and washers. Connect the combustion air flex hose to the burner flange adaptor and secure with retaining clamp.

For CM2 boiler model 246 and 311 only

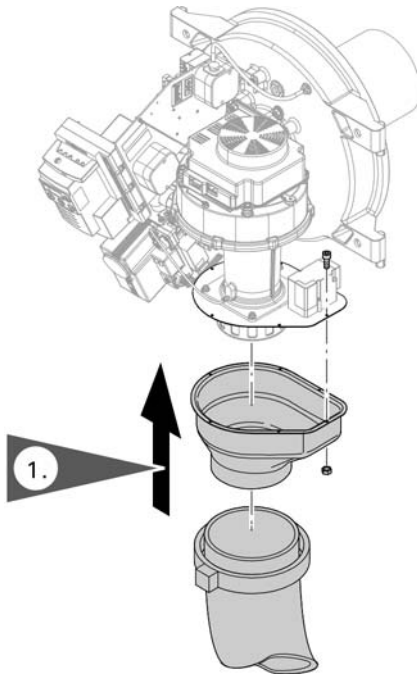

1. Install the combustion air intake adaptor to the burner air inlet using six M4 x 10 bolts, nuts and washers. Connect the combustion air flex hose to the burner flange adaptor and secure with retaining clamp.

Side Panels

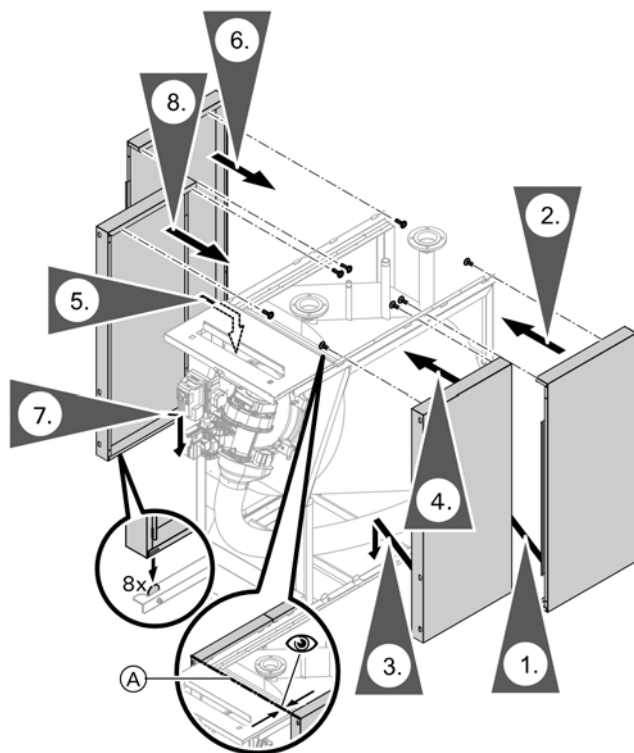

Note: Adjust the side panels to line up with the front panel (A) before securing with screws.

1. Install rear right side panel. Observe aligning notches and cutouts.
2. Secure rear right panel to top rail with two 4.8 metal screws.
3. Install middle right side panel. Observe aligning notches and cutouts.
4. Secure middle right panel to top rail with two 4.8 metal screws.
5. Install rear left side panel. Observe aligning notches and cutouts.
6. Secure rear left panel to top rail with two 4.8 metal screws.
7. Install middle left side panel. Observe aligning notches and cutouts.
8. Secure middle left panel to top rail with two 4.8 metal screws.

Side Panels (front)

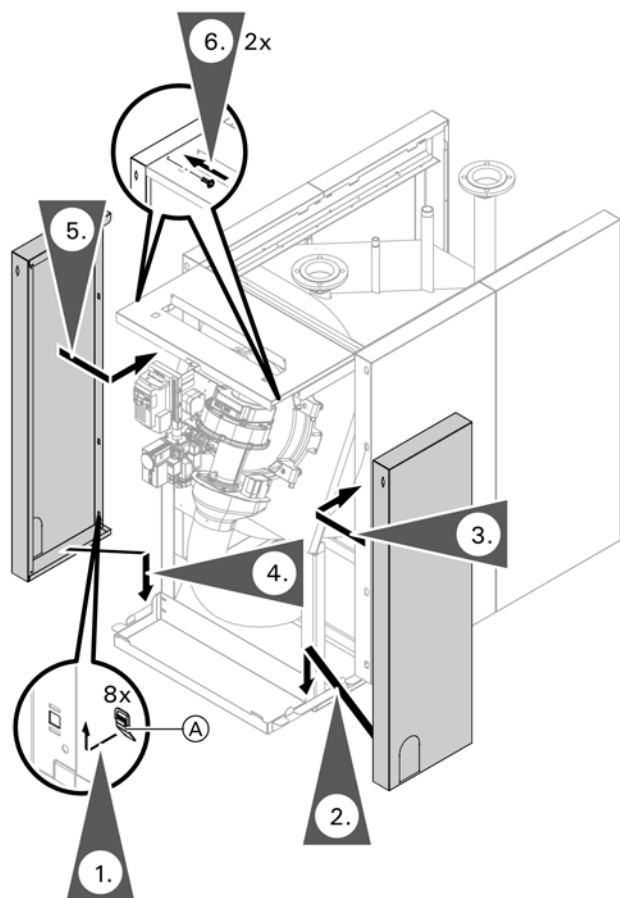

1. Insert spring clips (A) facing downwards into cut outs of right and left front side panels.
2. Install right front side panel to bottom rail. Observe aligning notches and cutouts.
3. Install right front side panel to middle side panel. Observe clips and cutouts.
4. Install left front side panel to bottom rail. Observe aligning notches and cutouts.
5. Install left front side panel to middle side panel. Observe clips and cutouts.
6. Secure both front panels to the top rails with two M5 screws.

Legend

- (A) Clips (included in the accessories package).

Flue Gas Temperature Switch

Flue temperature switch

Boilers with a polypropylene flue gas collector are supplied with a flue gas temperature switch, which must be installed.

Boilers with a stainless steel flue gas collector do not have provisions for a sensor well but may connect an optional flue gas temperature switch in the venting system. Contact your venting supplier.

This temperature switch is factory set to 212°F (100°C). Do Not Adjust.

During the operation of the boiler, should the switch become activated (open as a safety cut-out), check the boiler control for a C1 fault on the display. Also check the flue gas collector and/or vent system for any damage.

The temperature switch can be reset once the temperature drops approximately 20°F (10°C) from the factory set point.

Installing the Flue Gas Temperature Switch

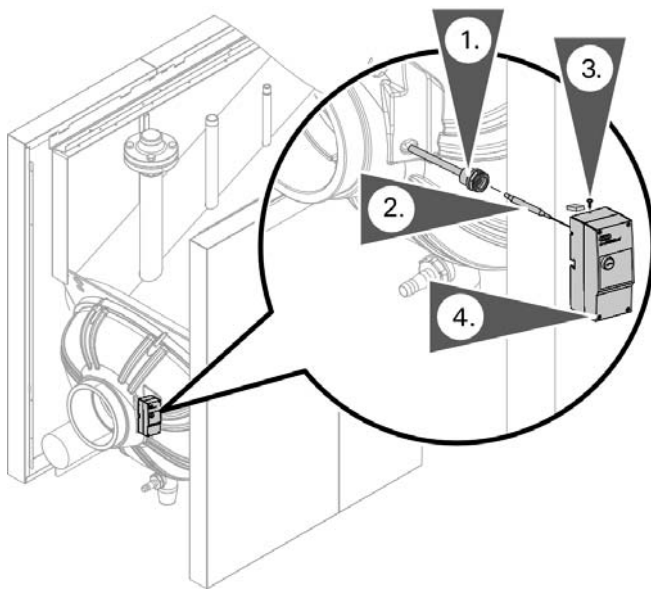

1. Install the sensor well into the flue gas collector and torque to 44 lb/in (5 Nm).
2. Insert the temperature probe into the sensor well.

IMPORTANT

Careful not to damage the temperature probe or capillaries during installation.

3. Insert the support bar into the back of the temperature switch. Push the temperature switch against the sensor well and secure the switch to the sensor well with a screw.
4. Remove the 4 cover screws and the cover.
5. Install the flue pipe adaptor to the flue gas collector and secure with the supplied gear clamps.

Wiring the Flue Gas Temperature Switch

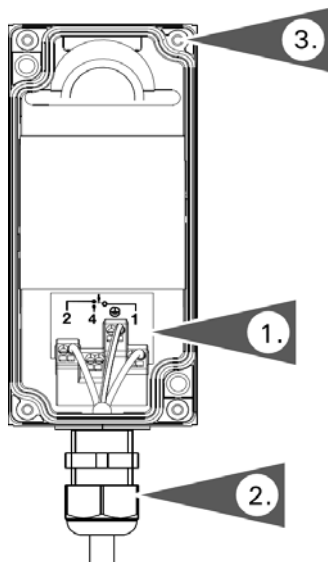

1. Connect the wiring to the switch terminals.
2. Connect the switch box cable connector..
3. Reattach the cover with the 4 screws.

Note: For junction box and control connection see page 21.

Rear Panels

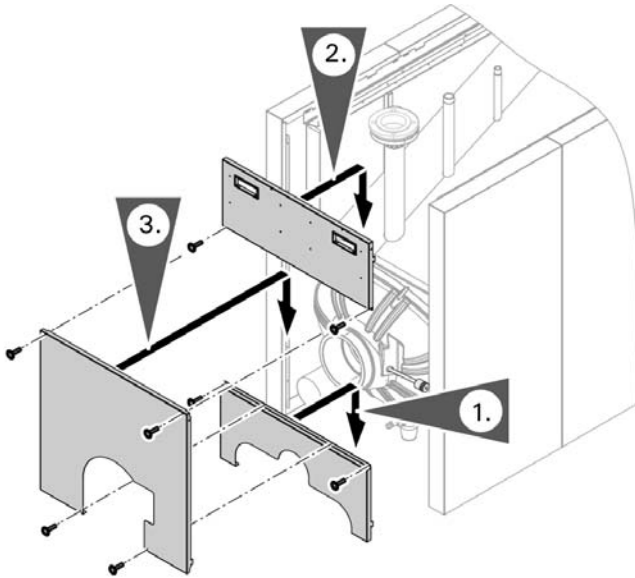

1. Install rear lower panel and secure with screws.
2. Install rear upper panel and secure with screws.
3. Install rear middle panel and secure with screws.

Note: The gap in the middle rear panel is for inspection of the flue gas temperature sensor.

Boiler Control and Junction Box

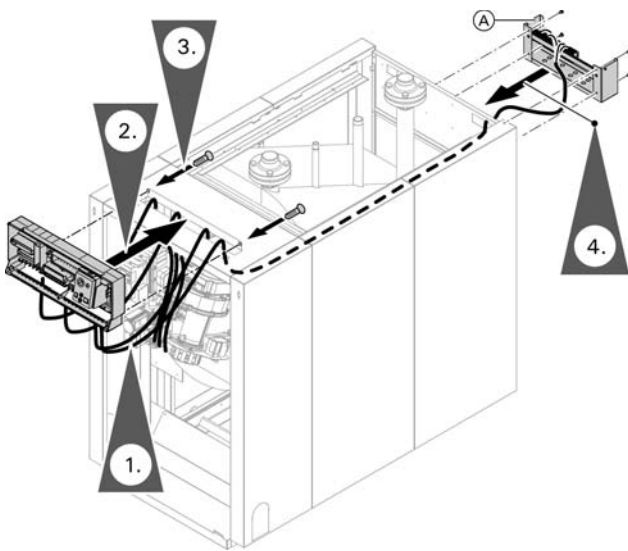

1. Route cables and capillaries from control through the opening in the control panel. Guide the cables to the junction box through the opening in the rear panel and along the top rail to the control. Secure all cables to the rail with cable ties. Insert temperature probe into the sensor well.

Note: Never allow cables to come in contact with hot metal components.

! WARNING

Do not bend or kink the capillaries. Damaging the capillaries leads to malfunction.

2. Mount the control to the control panel.
3. Secure the control to the control panel with screws.
Note: Screws to secure control are included in control's shipping box.
4. Install the junction box to the rear panel either right or left. Secure the junction box with four 4.8 mm metal screws.

Note: The ground screw and ground wire can be removed and then reinstalled with the boiler back panel attached.

Legend

Ⓐ Junction box

Flue Gas Temperature Switch Connection

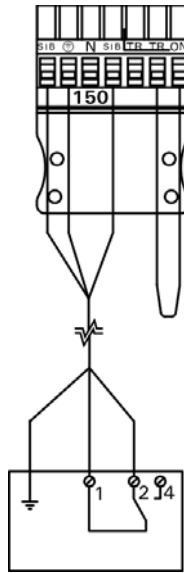

Refer to the Vitotronic Installation and Service Instructions for details.

Sensors and Buffer Panel

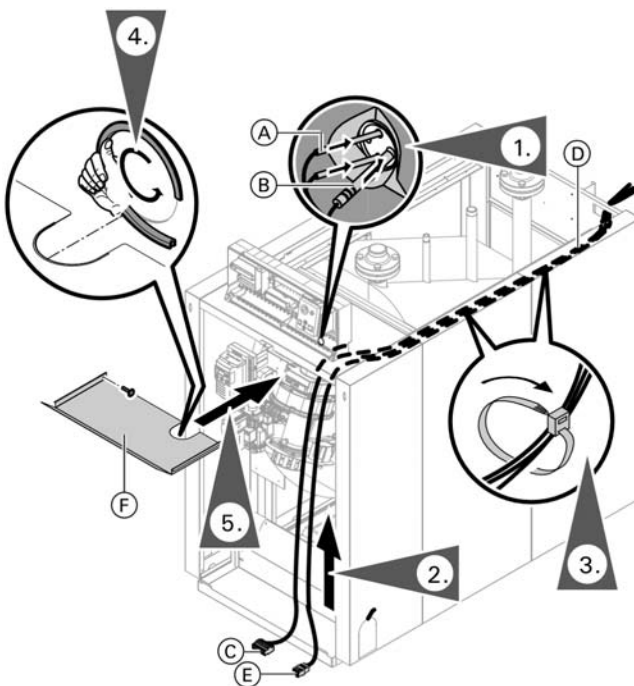

The boiler water temperature sensor (B) is included in control's shipping package. Plug (40) is plugged into control. Burner cables (41) and (90) are included in the insulation shipping package.

! WARNING

Do not bend the capillaries. Damaging the capillaries leads to malfunction.

! CAUTION

Never allow cables to come in contact with hot metal components.

1. Insert the sensors (A), (B) as far as possible into sensor well.
2. Guide cables through the control panel opening and along the top rail through the opening in the rear panel to the junction box.
3. Secure all cables to the rail with cable ties.
4. Secure metal edges of buffer panel with edge guards (included in insulation shipping package).
5. Install buffer panel to the top rails and secure with 4.8 mm metal screws.

Legend

- (A) Sensor
- (B) Boiler temperature sensor
- (C) Burner cable
- (D) Electrical connection cable
- (E) Flue gas temperature switch (if required)
- (F) Buffer panel

Top Panels

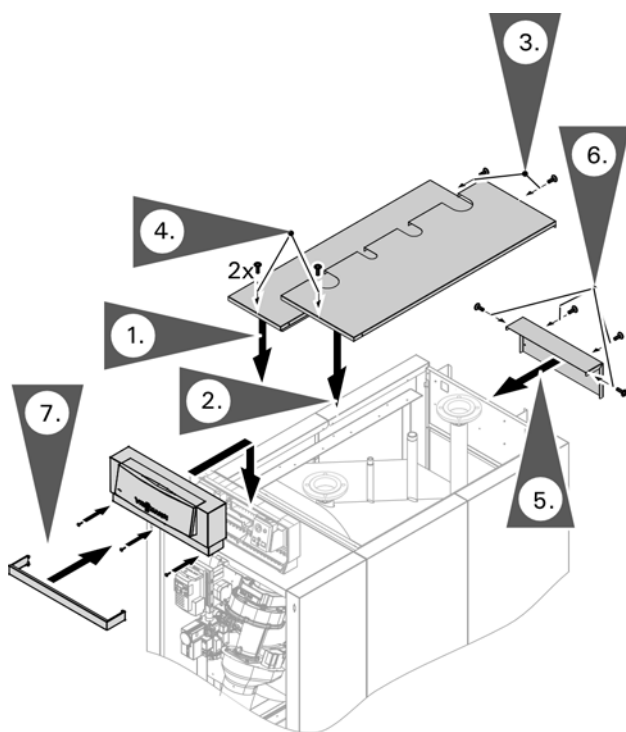

1. Install top left panel.
2. Install top right panel.
3. Secure the rear of both panels with metal screws.
4. Secure the front of both panels with metal screws.
5. Install top panel of the junction box.
6. Secure the top panel of the junction box with four metal screws.
7. Install control cover with 3 screws and snap on control cosmetic cover.

Flue Gas Connections

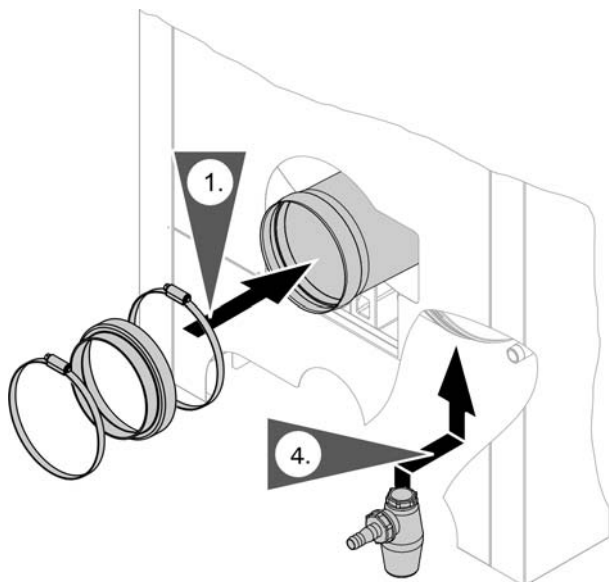

1. Install the flue gas adaptor to the flue gas collector and secure with the supplied gear clamps.
2. Fully insert flue gas adapter inside the flue outlet (if used with stainless steel piping).
Note: Connect the flue outlet with the flue pipe via the shortest possible run, with slight rise (min 3°). Avoid sharp bends.
3. Connect flue system. Size: 8 in. (200 mm).
Note: Support all venting components; make all connections free of load and torque stresses. The venting system must be securely supported by an anchoring system as outlined by the venting manufacturer.

IMPORTANT

The boiler flue gas collector vent is not designed to support the weight of the venting system.

4. Fill the siphon with water and attach to boiler.

Condensate Connection

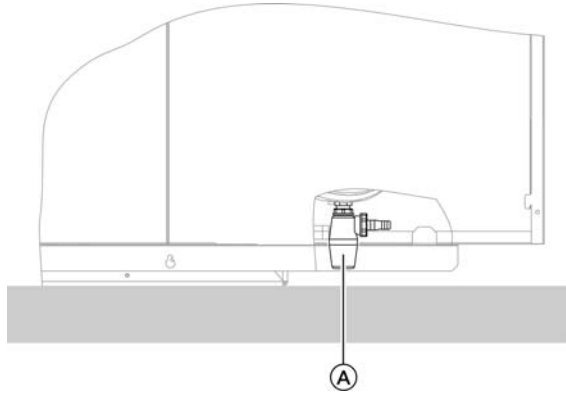

Legend

- (A) Condensate drain (must be able to be inspected)
- (B) Open or vented field supplied drainage system

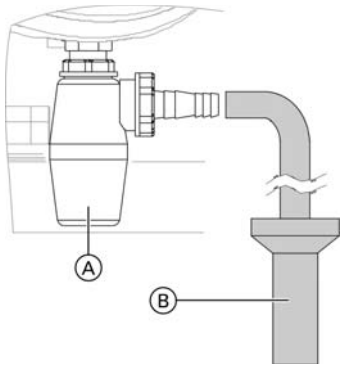

Note: If the boiler is installed even with the ground, install a condensing drain above the ground max. 2 in. (50 mm).

The Vitocrossal CM2 boiler comes with a built-in condensate trap (field installed). An external trap is not required when connecting the field drain to the P-trap. Discharge tubing (field supplied) must be 1 in. diameter. Use CPVC, PVC or other material approved by code listed below.

The drain pipe and fittings must conform to ANSI standards and ASTM D1785 or D2846. CPVC or PVC cement and primer must conform to ASTM D2564 or F493. In Canada use CSA or ULC listed schedule 40 CPVC or PVC drain pipe, fittings and cement.

1. Install the condensate drain pipe with a suitable gradient.
2. Discharge condensate from the boiler into the drain system, either directly or (if required) via a neutralization unit (accessory).

IMPORTANT

Do not connect the drain pipe from any other appliance, such as a water softener backwash pipe, to the CM2 condensate drain pipe.

IMPORTANT

Pipe ventilation must take place between the siphon trap and the neutralization unit (if applicable).

IMPORTANT

Always connect the drain with a P-trap or siphon to prevent flue gas from escaping into the space.

Connection (external): $\varnothing 3/4$ in. (19 mm) barb fitting

The amount of condensate to be expected during the operation of the boiler and can be read from the chart.

If the condensate outlet of the Vitocrossal 200 boiler is lower than the drain, a condensate pump must be installed. Select a pump which is approved for condensing boiler applications. To avoid condensate spillage, select a pump with an overflow switch. The drain connection must terminate into an open or vented drain as close to the boiler as possible to prevent siphoning of the boiler drain.

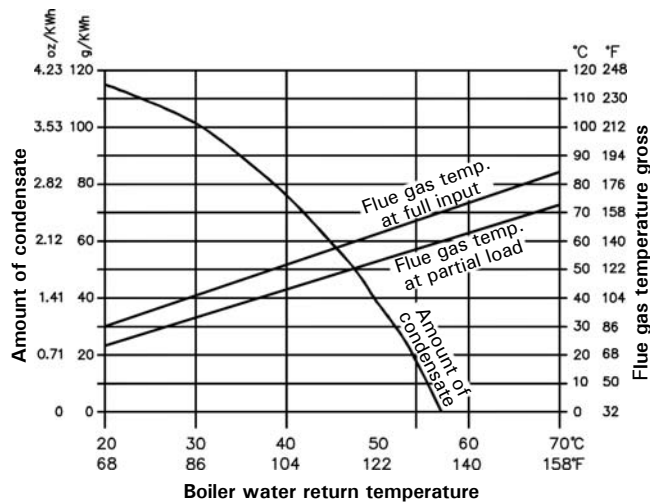

Note: The 'amount of condensate' and the "flue gas temperature gross" graphs are independent of each other.

Gas Connections

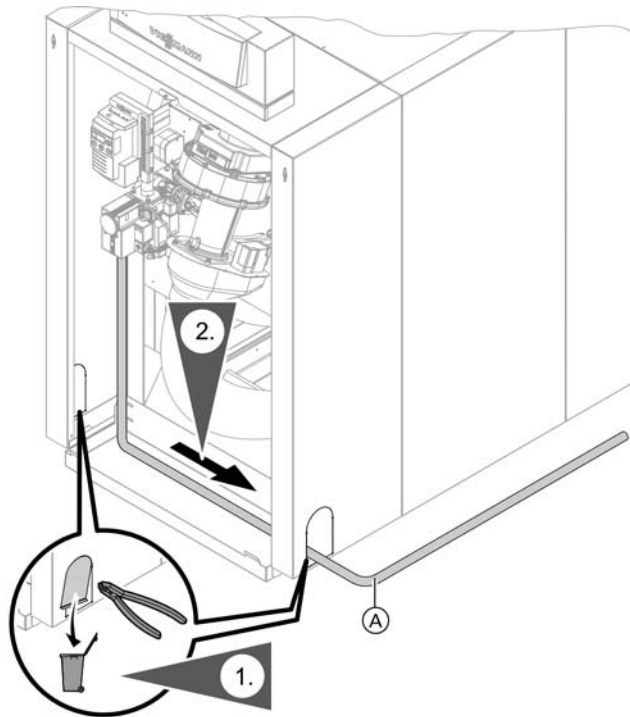

The gas train on the burner meets the requirement of ASME/CSD-1.

1. Cut out the aperture in front side panel either left or right.

Note: For ease during burner maintenance, route the gas supply pipe from the opposite side of the burner hinges (otherwise the panel cannot be removed when swinging burner left or right). See page 26.

2. Connect gas pipe (A) to the gas valve.

Gas connection:

Boiler model 186: 1 in. NPT

Boiler models 246 / 311: 1 ¼ in. NPT

3. The inlet gas connection flange kit is included with the burner (field mounted). The flange kit provides an inlet connection for the gas valve. The flange kit consists of:

- Gas valve flange (D) with measurement port (F)
- O-ring (C)
- Screws (E) (x4)

4. Test leak tightness of gas pipe connection.

! WARNING

If test pressure is too high burner and gas fittings may get damaged.

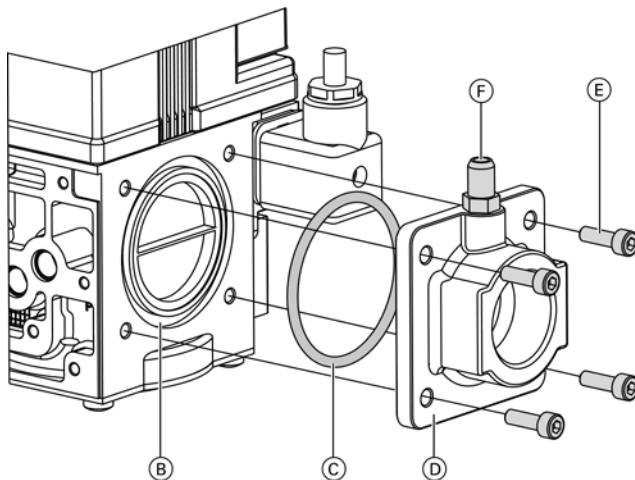

! WARNING

Escaped gas may lead to explosion, which could cause severe injuries. Do not vent gas pipe above combustion chamber of boiler.

5. Purge gas line in a safe manner using an approved purge burner.

! CAUTION

If gas pipe contains dirt it is recommended to install a gas filter into the gas pipe.

Legend

- (A) Gas pipe
- (B) O-ring groove
- (C) O-ring
- (D) Gas valve flange
- (E) Mounting screws
- (F) Pressure measurement port

Gas valve flange installation

1. Make sure the O-ring surfaces (B) are clean.
2. Apply a moderate amount of good quality pipe dope, resistant to the action of liquid propane gas (LPG) on the gas threads.
3. Screw the flange into the pipe.
4. Using general purpose lithium grease, grease the O-ring (C) provided with the flange kit and install at the inlet of the valve.
5. Tighten the screws to secure the flange (D) to the valve body. Torque screws (E) to 30 in/lb (3.5 Nm).

Gas Connections *(continued)*

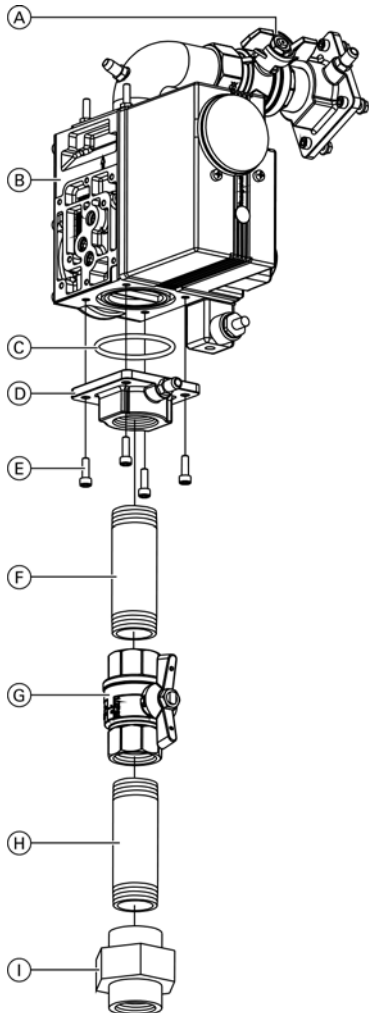

Legend

- (A) Manual test firing valve
- (B) Gas Valve
- (C) O-ring
- (D) Gas valve flange
- (E) Mounting screws
- (F) Nipple
- (G) Manual gas shutoff valve
- (H) Nipple (field supplied)
- (I) Ground joint union (recommended) (field supplied)

⚠ WARNING
 Escaped gas may lead to an explosion, which could cause severe injuries or property damage.

1. Refer to current CAN/CSA B149.1 and .2 or National Fuel Gas Code ANSI Z223.1/NFPA 54, as well as local codes for gas piping requirements and sizing. Pipe size to the boiler must be determined based on:
 - pipe length
 - number of fittings
 - type of gas
 - maximum input requirements of all gas appliances in the residence.

IMPORTANT

Design piping layout in such a way that piping does not interfere with serviceable components.

2. Before connecting boiler to gas line, install ground joint union, capped drip leg and a manual equipment shutoff valve. Valves must be listed by a nationally recognized testing agency. Make boiler gas connection as shown.
3. Perform gas piping pressure test as described in the following subsection.

IMPORTANT

Max. gas supply pressure: 14 "w.c.

4. Identify shutoff valves as such with a tab and familiarize operator/ultimate owner of boiler with these valves.



See Vitocrossal 200 CM2 Service Instructions for applicable system coding information.

Valve leak test

This a test for checking the leak tightness of the valve and flange connections. It is recommended that this test be included in the scheduled inspection and maintenance procedures.

IMPORTANT

This test should only be performed by a trained licensed heating contractor.

1. Close the manual test firing valve (A).
2. Open the manual gas shutoff valve (G).
3. Leak test all connections with a certified leak detector.
4. Close the manual gas shutoff valve (G).
5. Open the manual test firing valve (A).
6. Repair any leaks if necessary.

Note: When required, install the supplied auxiliary low gas pressure switch. Follow the low gas pressure switch instructions.

Front Panel (door)

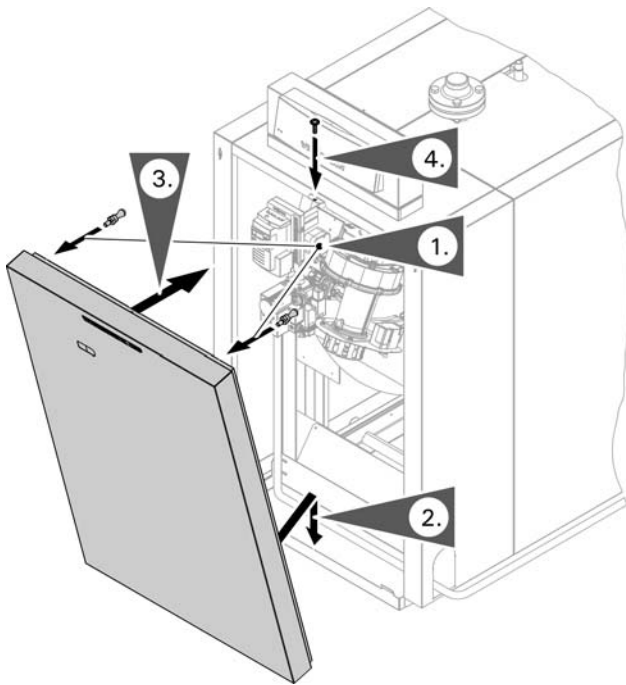

1. Screw profile studs into the threads of the front panel (door).
2. Insert front panel retainers into the notches on the bottom panel.
3. Tilt up the door and snap door into place.
4. Secure door with M5 screw.

Boiler Piping in Heating / Cooling Application

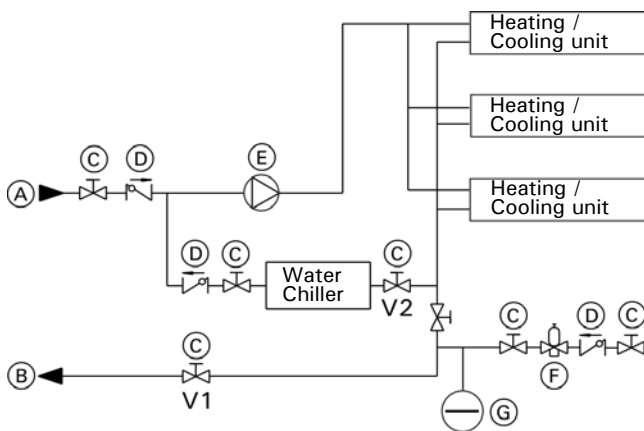

Legend

- (A) System supply
- (B) System return
- (C) Valve
- (D) Flow check valve
- (E) Circulation pump
- (F) Automatic feed valve
- (G) Pre-charged expansion tank

The boiler, when used in connection with a refrigeration system, must be installed so that the chilled medium is piped in parallel to the boiler and with appropriate valves to prevent the chilled medium from entering the boiler.

The boiler piping system of a hot water heating boiler is connected to the heating coils located in the air handling units. The boiler piping system may be exposed to refrigerated air circulation and must be equipped with flow control valves or other automatic means to prevent gravity circulation of the boiler water during the cooling cycle.

Check the installation instructions of the chiller manufacturer carefully for additional requirements.

Cooling season starts: Close valve V1 and open valve V2.

Heating season starts: Close valve V2 and open valve V1.

Metal tags labelling these valves should be attached.

IMPORTANT

In the above system, the circulating pump must be operated from a separate on/off switch - not from the boiler control.

Initial System Fill

Treatment of boiler feed water should be considered in areas of known problems, such as high mineral content and hardness. In areas where freezing might occur, an antifreeze may be added to the system water to protect the system (maximum mix ratio - 50% / 50%). Please adhere to the specifications given by the antifreeze manufacturer for hydronic heating systems.

IMPORTANT

Only use antifreeze specific for hydronic heating systems. Do not use automotive glycol!

Please observe that an antifreeze/water mixture may require a backflow preventer within the automatic water feed and influence components such as diaphragm expansion tanks, radiation etc. A 40% antifreeze content will provide freeze-up protection to -31°F (-25°C).

The heating system may also contain components which may be negatively affected by antifreeze. Check entire system frequently when filled with antifreeze. Read boiler service instructions for further information on water quality.



CAUTION

Before the heating boiler is installed and piped into an existing system, the heating system itself must be properly flushed to remove dirt and system sludge. Accumulations in old heating systems will tend to settle in the boiler and can lead to deposits which can cause hot spots, noise and water-side corrosion. For damages resulting from those kinds of impurities, the warranty will be null and void.

The Vitocrossal 200 boiler is only suitable for closed hot water heating systems with pumps.

It is strongly recommended to install boiler isolation valves and above these isolation valves, drain valves in the system supply and return. With this installed, any maintenance work on the boiler or heating system, will not require draining the entire system.

When the boiler is utilized to supply heat to an indirectly heated domestic hot water tank, it is necessary that the heating loops (without a mixing valve) are equipped with flow check valves on the discharge side of the pumps to avoid reverse flow.

IMPORTANT

All system pumps must be installed from boiler supply to the system.

The pressure relief valve must be attached to the top of the boiler or the safety supply of the boiler, see page 13. No valve, shut-off device or obstruction of any kind and no construction must be used between boiler and relief valve or on the discharge side of the pressure relief valve.

The discharge side of the pressure relief valve must continue in the same size as the outlet horizontally over the side of the boiler, and then vertically downwards to end approximately 1 ft. (300 mm) above the floor, and piped as close to a floor drain as possible. Do not install this discharge pipe to the outdoors or any area where freezing might occur or the discharge pipe could endanger life and equipment.

IMPORTANT

Secure the discharge piping from the pressure relief valve with the appropriate hangers or brackets.

The boiler should be filled and properly bled of air.

All openings, as well as pipe connections on the boiler, should be observed for possible leaks. Once all connections are tight, the insulation can be mounted.

IMPORTANT

Cold water fill pressure must equal expansion tank pressure.

The boiler should be filled and properly bled of air and the cold water fill pressure should not exceed 18-20 psig. All openings, as well as pipe connections on the boiler, should be observed for possible leaks. Once all connections are tight, the insulation can be mounted.

IMPORTANT

Ensure that there is no leak on any of the connections which are covered by the insulation.



WARNING

Fill only suitable water in boiler (refer to Service instruction). Unsuitable water quality may damage boiler.

General Venting Information

Installation steps (outline)

WARNING

Ensure that the entire venting system is protected from physical damages. A damaged venting system may cause unsafe conditions.

WARNING

The venting system is approved for indoor installations only. Do not install the venting system outdoors.

IMPORTANT

Boiler operation in marine environments (damp, salty coastal areas):

The service life of the boiler's exposed metallic surfaces, such as the casing and fan housing, is directly influenced by proximity to damp and salty marine environments. In such areas, higher concentration levels of chlorides from sea spray, coupled with relative humidity, can lead to degradation of the exposed metallic surfaces mentioned above. Therefore, it is imperative that boilers installed in such environments not be installed using direct vent systems which draw outdoor air for combustion. Such boilers must be installed using room air dependent vent systems; i.e. using room air for combustion. The indoor air will have a much lower relative humidity and, hence, the corrosion will be minimized.

- Route vent pipe as directly as possible and with as few bends as possible to the boiler.
- Check proper location of gaskets in rigid PP pipe collars. (Only use supplied parts with the polypropylene venting system.) Apply water to lubricate the joint ends of the vent pipe collar and if used, the air intake pipe collar.
- Slide pipes into each other with a gentle twisting motion.
- Condensate must drain from the flue pipe to the boiler. Ensure a suitable gradient of at least 3° [approx. 2 in. per 3.3 ft. (50 mm per 1 m)].
- Use a hacksaw or sheet metal snips (for stainless steel) to cut pipes to length (if necessary). Use a file to smooth rough edges. Pipe must be round and not bent into an oval shape.

IMPORTANT

When cutting pipes to length, debur and clean pipes.

- For stainless steel and PP venting systems: In conjunction with these instructions, follow the installation instructions supplied by the special venting manufacturer.

Combustion air intake, flex hose and adaptor must be installed. If using room air-independent venting system, connect the air intake pipe (from outdoors) to the adaptor provided. If room air-dependent venting system is used, the air is drawn into the burner inlet through adaptor and flexible pipe. (See figure from page 11 and 16).

Recommended Venting Practice

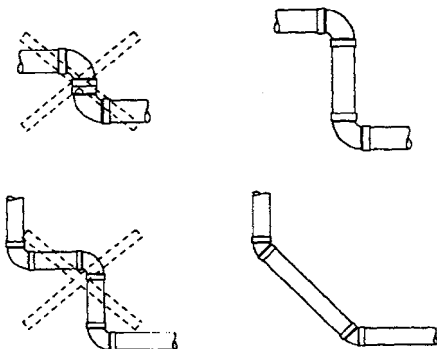

When installing a venting system the following recommended venting practices apply:

- Keep length and number of 90° elbows to a minimum.
- Try not to use back-to-back 90° elbows.
- Use 45° elbows where possible to minimize the number of 90° elbows in case redirection of flue gas is required.
- The special vent system shall not be routed into, through, or within any other vent such as an existing masonry or factory-built chimney.

Exception:

A masonry chimney flue may be used to route the venting system only if no other appliance is vented in the same flue.

General Venting Information *(continued)*

Approved venting materials

Part	Material	Certified to Standards	Applicability
Exhaust pipe and fittings	Stainless steel	UL1738 "Venting systems for gas-burning appliances, Categories II, III, IV"	U.S.A./Canada
		ULC S636 "Standard for Type BH gas venting systems"	
	PP Polypropelene	UL1738 "Venting systems for gas-burning appliances, Categories II, III, IV"	
		ULC S636 "Standard for Type BH gas venting systems" Class IIC 110°C	
Combustion air intake pipe and fitting	Stainless steel	n.a.	
	PVC-DWV Schedule 40	ANSI/ASTM D2661 CSA B181.1 ULC S102.2 ANSI/ASTM D2665, D1785 CSA B137.3, B181.2 ANSI/ASTM F441	
	CPVC Schedule 40	ANSI/ASTM D2661 CSA B181.1 ULC S102.2 ANSI/ASTM D2665, D1785 CSA B137.3, B181.2 ANSI/ASTM F441	
	ABS-DWV Schedule 40	ANSI/ASTM D2661 CSA B181.1 ULC S102.2 ANSI/ASTM D2665, D1785 CSA B137.3, B181.2 ANSI/ASTM F441	
	PP Polypropelene	UL1738 "Venting systems for gas-burning appliances, Categories II, III, IV"	
ULC S636 "Standard for Type BH gas venting systems" Class IIC 110°C			
Pipe cement, primer (for combustion air intake pipe)	PVC	ANSI/ASTM D2564 CSA B137.3	
	CPVC	ANSI/ASTM F493 CSA B137.6	
	ABS	ANSI/ASTM D2235 CSA B181.1/B182.1	

⚠ CAUTION
On the job site, ensure that non-listed combustion air pipe materials are not inadvertently used instead of listed vent pipe material.

⚠ CAUTION
Do not use cellular (foam) core pipe material to vent this Vitocrossal boiler.

General Venting Information *(continued)*

Vent termination location requirements (for installations in Canada)

The vent must be installed observing local regulations in addition to National Codes, CAN/CSA-B149.1 or 2. The flexible vent pipe can only be used in vertical installations. A vent must **NOT** terminate...

- 1.....directly above a paved sidewalk or paved driveway which is located between two single-family dwellings and serves both dwellings.
- 2.....less than 7 ft. (2.13 m) above a paved sidewalk or a paved driveway located on public property.
- 3.....within 6 ft. (1.83 m) of a mechanical air supply inlet*¹ to any building (dryer vents, non-sealed combustion furnace and hot water heater vents are considered to be mechanical air inlets).
- 4.....above a meter/regulator assembly within 3 ft. (0.9 m) horizontally of the vertical centerline of the regulator vent outlet and to a maximum vertical distance of 15 ft. (4.5 m).
- 5.....within 3 ft. (0.9 m) of any gas service regulator vent outlet.
- 6.....less than 1 ft. (0.3 m) above grade level or anticipated snow level (consult local building authorities or local weather office). Locate the vent termination in such a way that it cannot be blocked by snow.
- 7.....within the following distances of a window or door which can be opened in any building, any non-mechanical air supply inlet to any building or the combustion air inlet of any other appliance:
 - 1 ft. (0.3 m) for inputs up to and including 100 000 Btu/h / 30 kW.
 - 3 ft. (0.9 m) for input exceeding 100 000 Btu/h / 30 kW.

- 8.....underneath a veranda, porch or deck, unless:
 - the veranda, porch, or deck is fully open on a minimum of two sides beneath the floor, and
 - the distance between the top of the vent termination and the underside of the veranda, porch, or deck is greater than 1 ft. (0.3 m).
- 9.....in areas where condensation may cause problems, such as above planters, patios, or adjacent to windows where flue gases may cause fogging.
- 10....within 3 ft. (0.9 m) to the property line (advisable, not mandatory; please check with local building authorities and municipal bylaws).
- 11....at a location where ice formation on the ground can present a hazard.
- 12....so that the flue gases are directed toward brickwork, siding, or other construction, in such a manner that may cause damage from heat or condensate from the flue gases.
- 13....where discharging hot flue gases may cause property damage or personal injury.
- 14....within 3 ft. (0.9 m) from an inside corner of outside walls.

*¹ Including heat recovery units.

Vent Termination Location Requirements (for installations in the U.S.A.)

The vent must be installed observing local regulations in addition to National Codes, ANSI-Z223.1 or NFPA 54. The flexible vent pipe can only be used in vertical installations. A vent must **NOT** terminate...

- 1.....less than 7 ft. (2.13 m) above a paved sidewalk or a paved driveway located on public property.
- 2....within 4 ft. (1.2 m) horizontally from service regulator vents, electric and gas meters as well as relief equipment.
- 3....at least 3 ft. (0.9 m) above any forced air inlet located within 10 ft. (3 m).
- 4.....less than 1 ft. (0.3 m) above grade level or anticipated snow level (consult local building authorities or local weather office). Locate the vent termination in such a way that it cannot be blocked by snow.
- 5.....within 1 ft. (0.3 m) of a window or door which can be opened in any building, any non-mechanical air supply inlet to any building or the combustion inlet of any other appliance.
- 6.....in areas where condensation may cause problems, such as above planters, patios, or adjacent to windows where flue gases may cause fogging.
- 7.....within 3 ft. (0.9 m) to the property line (advisable, not mandatory; please check with local building authorities and municipal bylaws).
- 8.....at a location where ice formation on the ground can present a hazard.
- 9.....so that the flue gases are directed toward brickwork, siding, or other construction, in such a manner that may cause damage from heat or condensate from the flue gases.
- 10....where discharging hot flue gases may cause property damage or personal injury.
- 11....within 3 ft. (0.9 m) from an inside corner of outside walls.

General Venting Information *(continued)*

Flashing and storm collar installation

Flashings and storm collars are field supplied. Flashings and storm collars suitable for Type B vent materials (or better) may be used.

To obtain flashings and storm collars, please contact your local vent material supplier. Follow the installation instructions supplied by the special venting manufacturer.

Follow local codes to properly isolate the exhaust vent pipe when passing through floors, ceiling and roof.

Always check the marking on the pipe to make sure you are using the correct material.

Additional Requirements for Stainless Steel Vent Pipe Material

Use stainless steel venting system (UL/ULC listed for category IV) for horizontal or vertical venting of the Vitocrossal boilers.
Contact one of the suppliers (see listing on right) to order.
Prior to installation, check that the correct single-wall vent parts were ordered and supplied.

Exhaust vent/air intake connection to boiler

The vent connection to the Vitocrossal boiler must be made with the starter stainless steel adaptor (supplied by others).

Combustion air intake, flex hose and adaptor must be installed. If using room air-independent venting system, connect the air intake pipe (from outdoors) to the adaptor provided. If room air-dependent venting system is used, the air is drawn into the burner inlet through adaptor and flexible pipe. (See figure from page 11 and 16).

IMPORTANT

For exhaust vent pipe material:
Do not use any other vent material.



WARNING

The use of vent material other than listed UL/ULC stainless steel and PPs positive pressure vent pipe and fittings can cause property damage, severe personal injury and/or loss of life.

<p>M&G / Duravent Tel. 800-835-4429 Tel. 518-649-9700 Fax: 518-463-5271 Email: sales@duravent.com Web: www.duravent.com</p>	<p>ICC - Industrial Chimney Co. 400 J-F Kennedy, St-Jerome, Quebec Canada, J7Y 4B7 Tel. 514-565-6336 Fax: 514-565-6519 Email: sales@ICC-RSF.com</p>
<p>Selkirk Canada Corporation 375 Green Road Stoney Creek, ON L8E 4A5 Tel.: (905) 662-6600 Fax: (905) 662-5352 (US) 1-800-992-8368 (Canada) 1-888-735-5475 Email: info@selkirkcorp.com Web: www.selkirkchimney.com</p>	<p>Novaflex 1-20 East Pearce St., Richmond Hill, Ontario, Canada, L4B 1B7 Tel. 905-731-9411 Email: sales@flexmaster.com</p>
<p>Wesmech Technical Sales 50 Ronson Drive, Suite 160 Toronto, ON M9W 1B3 Tel.: (416) 251-8990 Fax: (416) 251-8900 1-800-613-3789 Email: info@wesmechtech.com Web: www.wesmechtech.com</p>	<p>Van-Packer Co. Inc. 302 Mill Street PO Box 307 Buda, IL 61314 Tel.: (309) 895-2311 Fax: (309) 895-3891 1-888-877-8225 Email: vpstack@theramp.net Web: www.vpstack.com</p>
<p>Security Chimneys International Ltd. 2125 Rue Monterey, Laval, Quebec H7L 3T6 Tel. 450-973-9999 (US) 1-800-361-4909 (Canada) 1-800-667-3387 Fax: 450-973-2222 Email: infoeng@securitychimneys.com Web: www.securitychimneys.com</p>	<p>Energex Inc. (formerly Exhausto) Tel: 770-587-3238 Fax: 770-587-4731 (800) 225-2923 Email: info@exhausto.com Web: www.vpstack.com</p>

Note: For SS venting system order transition adaptors from the above mentioned suppliers.

Requirement for UL/ULC Listed Rigid SS/PP(s) Vent Pipe Material

Requirements for PP and stainless steel

The venting system must be installed by a licensed professional heating contractor familiar with the operation and maintenance of heating appliances and venting. Before installing, ensure that the complete installation literature has been read. Failure to follow proper installation procedures as stated in these instructions, including vent pitch and proper appliance connections, may violate local, provincial/state, or national codes and cause unsafe conditions which may lead to severe property damage or personal injury.

The venting system must be installed in accordance with local building code requirements as well as national codes. For installations in Canada use CAN/CSA-B149.1 Natural Gas Installation Code or CAN/CSA-B149.2

Propane Installation Code as applicable; in the U.S. use the National Fuel Gas Code ANSI Z223.1 or NFPA Standard 54.

To ensure safe operation of the appliance, Viessmann recommends that the system be inspected once a year by a qualified service technician.

Every venting system must be planned and installed for optimum performance and safety. These Installation Instructions are designed to help you determine venting requirements and limitations with respect to installation. Please read and follow these instructions carefully.

It is the responsibility of the installer to contact local building and fire officials concerning any installation restrictions and/or inspection requirements that may apply. Permits may be required before commencement of the installation.

The vent termination for side wall vent installations should be located on a wall that is least affected by prevailing winds. High winds may affect boiler operation and/or degrade the exterior finish of the wall. They may also cause recirculation of the appliance's own flue products. Recirculation of flue products can result in poor combustion and inlet condensation problems.

If wind is a problem, steps must be taken to shield the vent termination from high winds, such as building a fence or planting shrubs. Ensure that the total equivalent vent length is not exceeded.

Because of its sealed combustion chamber, the Vitocrossal 200 gas-fired condensing boiler is suitable for operation with balanced flue (when using air intake system).

Use only material listed in table on page 30, entitled "Approved venting materials".

IMPORTANT

Potential gaps between the vent/air intake pipes and the surrounding construction which may cause air, rain or flue gases to leak into the wall or the building, must be sealed with approved sealant /caulking to prevent leakage of any kind.

This PP vent system is constructed from flame-retardant plastic [polypropylene rated for a maximum temperature of 230°F (110°C)].

The PP venting system components must be listed to ULC S636 / UL-1738 (contact one of the venting suppliers below).

DO NOT mix pipe, fittings, or joining methods from different vent system manufacturers.

The vent length requirements stated in this manual (on page 39 for two pipe vent installations and page 43 for single pipe installations) must be observed.

If using flexible vent or air intake pipe, reduce the max. equivalent length allowed by 25%.

The PP venting material can be extended (without exceeding the maximum equivalent length) beyond the outside wall of the structure, provided that the PP venting material is installed in an enclosed, insulated and waterproof chase that is acceptable for outdoor installation. The vent termination location must comply with the instructions and codes stated in this manual.

IMPORTANT

Side wall vent installations must include Viessmann protective screen.

Vent System Suppliers

Use special venting system (UL/ULC listed for Category IV) for exhaust vent material of the Vitocrossal boilers. Contact one of the following suppliers to order parts.

Both suppliers deliver PP(s) rigid and flexible vents in three sizes.

M&G / Duravent	Centrotherm InnoFlue
8 in. (200 mm)	8 in. (200 mm)
M&G / Duravent Tel. 800-835-4429 Fax. 518-649-9700 Fax: 518-463-5271 sales@duravent.com www.duravent.com	Centrotherm InnoFlue Eco Systems. LLC 418 South Pearl St. Albany, New York 12202 Tel. (518) 434-3400 Fax. (518) 618-3166 info@centrotherm.us.com www.centrotherm.us.com

Vent Requirements

Combustion air supply, room air dependent application only

This boiler requires fresh air for safe operation and must be installed in a mechanical room where there are provisions for adequate combustion and ventilation air. There are provisions available on the Vitocrossal boiler to interlock it with an external combustion air blower.

Provisions for combustion and ventilation air must be made in accordance with CAN/CSA-B149.1 or .2 Natural Gas Installation Codes (latest edition) (for installations in Canada) or in accordance with sections for Combustion and Ventilation Air, of the National Fuel Gas Code, ANSI Z223.1 (latest edition) or applicable provisions of local codes (for installations in the U.S.A.)

Follow local codes to properly isolate the vent pipe when passing through floors, ceilings and roof.

Whenever possible, install boiler near an outside wall so that it is easy to duct fresh air directly to the boiler area. Refer to national codes for duct sizing. Round ducts may be used.

The boiler must be vented and supplied with combustion air and exhaust vents as described in this section. Ensure the vent and combustion air supply comply with these instructions. (See also page 29).



WARNING

Failure to provide an adequate supply of fresh combustion air can cause poisonous flue gases to enter living space, which can cause severe personal injury or loss of life.

The boiler location should never be under negative pressure. Exhaust fans, attic fans, or dryer fans may cause air to be exhausted at a rate higher than the air can enter the structure for safe combustion. Corrective action must be taken to ensure enough air is available. Never cover the boiler or store debris or other materials near the boiler, or in any way block the flow of adequate fresh combustion air to the boiler.

If boiler is installed in a confined space (a space with a volume of less than 50 cubic feet per 1000 Btu/h of gas input for all fuel burning equipment) or building layout is unusually tight, adequate air for combustion must be provided by two openings: one located about 6 in. below the ceiling, the other about 6 in. above the floor. When communicating directly with the outside, each opening must have a minimum free area of one square inch per 2000 Btu/h of gas input. When all combustion air is provided by openings in doors, etc. to adjoining spaces having adequate infiltration, each opening must have a minimum free area of one square inch per 1000 Btu/h of gas input, but not less than 100 in².

You must know the free area of louvers used to cover up the combustion and ventilation openings in closet installations. If you do not know the free area, assume 20% for wood louvers and 60-75% free area for metal louvers. When using louvers, the openings have to be made larger.

For example, a free 14 in. x 6 in. (356 mm x 152 mm) opening becomes a 14 in. x 10 in. (356 mm x 254 mm) opening for a grill containing metal louvers.



CAUTION

Do not store chemicals containing chlorine or other corrosive materials near the boiler, such as bleach, cleaning solvents, detergents, acids, hair spray, spray cans, paint thinners, paint, water softener salt, perchloroethylene, or carbon tetra chloride.

Direct Venting (Two Pipe System)

Side wall vent termination [stainless steel, CPVC or PP]

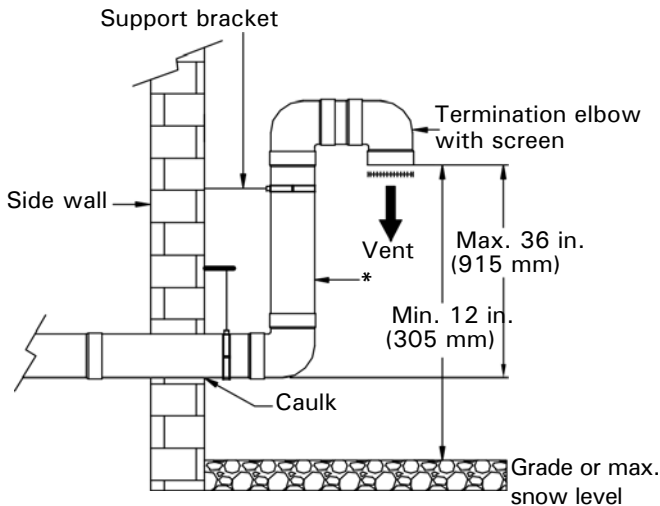
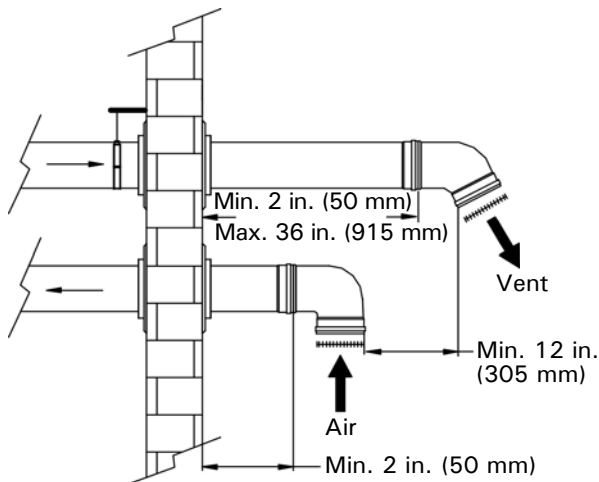
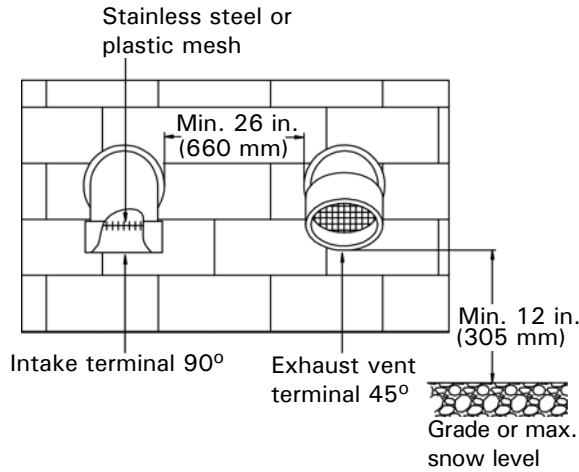

* Field fabricated vent riser

IMPORTANT

The exhaust vent/air intake system must terminate so that proper clearances are maintained as cited in local codes or the latest edition of the "Natural Gas and Propane Installation Code" CAN/CSA-B149.1 (Canada), or the "National Fuel Gas Code" ANSI Z223.1 (NFPA 54) (U.S.A.).

IMPORTANT

For PP systems, all exhaust vent and air intake piping and elbows exposed outside, must be UV resistant polypropylene (supplied by the vent manufacturer).

! WARNING

Vent termination must be at least 12 in. (305 mm) above the anticipated snow level (consult your local building authorities or local weather office). Locate vent termination in such a way that it cannot be blocked by snow.

Side Wall Venting

Side wall vent termination [stainless steel or PP]

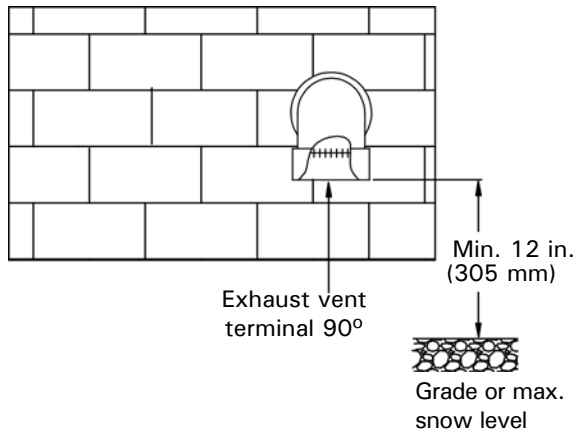

IMPORTANT

For PP systems, all exhaust vent and air intake piping and elbows exposed outside, must be UV resistant polypropylene (supplied by the vent manufacturer).

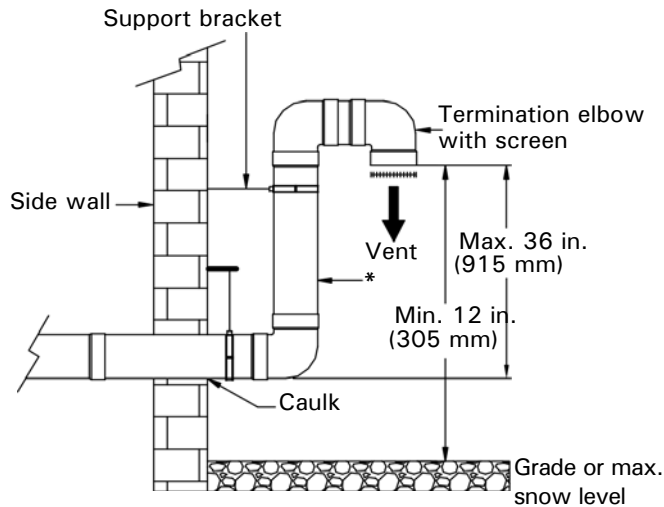
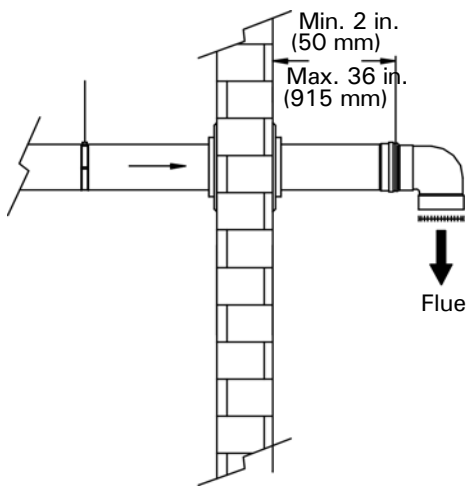

* Field fabricated vent riser

Component Installation Guide

Flashing and storm collar installation

Flashings and storm collars are field supplied. Flashings and storm collars suitable for Type B vent materials (or better) may be used.

To obtain flashings and storm collars, please contact your local vent material supplier. Follow the installation instructions supplied by the special venting manufacturer.

Vent Termination Location Requirements - Vertical

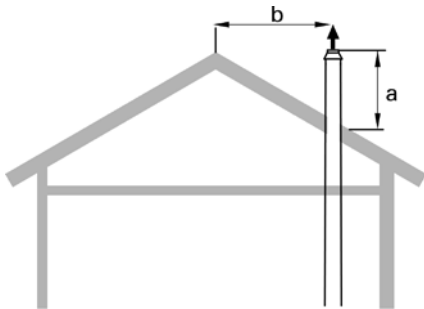

For sloped roof applications with distance b greater than 18 in. (450 mm)

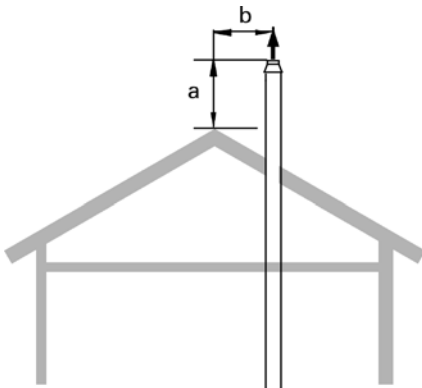

For sloped roof applications with distance b less than 18 in. (450 mm)

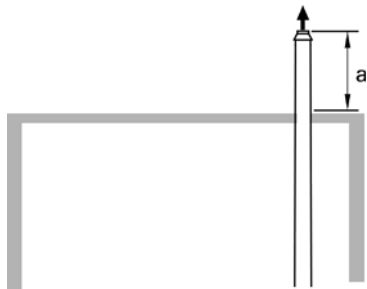

For flat roof applications

The vent must be installed observing local regulations in addition to National Codes, CAN/CSA-B149.1 or 2 (for installations in Canada) or ANSI-Z223.1 or NFPA 54 (for installations in the U.S.A.).

WARNING

Vent termination must be at least 12 in. (305 mm) above the anticipated snow level (consult your local building authorities or local weather office). Locate vent termination in such a way that it cannot be blocked by snow.

A vent used in a special venting system with positive vent pressure and passing through a roof shall extend at least 18 in. (450 mm) above the highest point where it passes through the roof and any other obstruction within a horizontal distance of 18 in. (450 mm).

The special vent system shall not be routed into, through, or within any other vent such as an existing masonry or factory-built chimney.

IMPORTANT

A masonry chimney flue may be used to route the venting system only if no other appliance is vented in the same flue.

Installation of Support System - PP

Bracing

Contact your local vent material supplier for more information specific to your installation. Braces are required to stabilize an installation. There are different types and their use and spacing vary.

The following types of braces are available at your local vent material supplier:

- wall band
- wall band extension
- guy wire band
- roof brace.

IMPORTANT

Ensure that the venting system is properly supported; the boiler is not designed to support the weight of the venting system.

Vent System Suppliers

To order approved PP(s) vent system contact the following suppliers.

M&G / Duravent Tel. 800-835-4429 Tel. 518-649-9700 Fax: 518-463-5271 sales@duravent.com www.duravent.com	Centrotherm InnoFlue Eco Systems. L.L.C. Tel. (877) 434-3432 Fax. (518) 618-3166 Email: info@centrotherm.us.com Web: www.centrotherm.us.com
--	---

IMPORTANT

**For exhaust vent pipe material:
Use only ULC S-636 / UL 1738 vent material.**

The venting system must be securely supported by a support system suitable for the weight and design of the materials employed. Contact your vent material supplier for more information specific to your installation.

Supports are used to transfer the weight of an installation to the building structure. There are different types of supports and their capacity varies with each type and diameter.

The following support types are available at your local vent material supplier:

- anchor plate
- wall support
- roof support
- floor support
- suspension band (hanger).

Long Sweep Elbows

Standard long sweep elbow equivalent length material

Material	90° elbow equivalent length ft. (m)	45° elbow equivalent length ft. (m)	87° elbow equivalent length ft. (m)
Stainless steel	3 (0.91)	2 (0.61)	---
CPVC plastic pipe	5 (1.52)	3 (0.91)	---
PP	---	1 (0.30)	1.6 (0.50)

Note: If flexible vent or air-intake pipe are used, the total max. equivalent length will be reduced by 25% [150 ft. (45 m)].

Two Pipe System - Vertical Exhaust / Vertical Air Intake

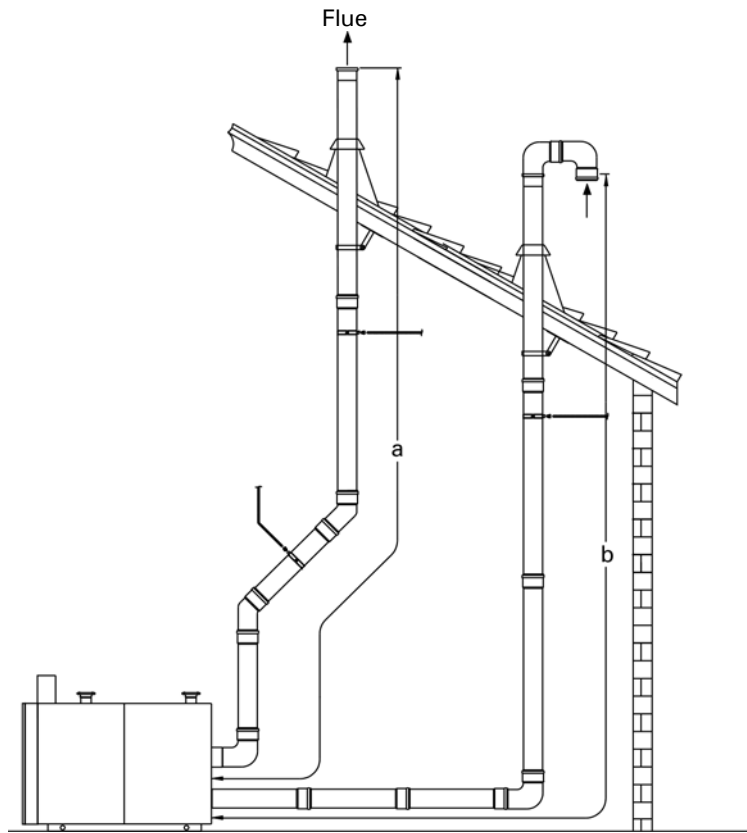

a - Equivalent length (exhaust)
b - Equivalent length (air intake)
Note: See table on page 40.

Two Pipe System - Vertical Exhaust / Vertical Air Intake *(continued)*

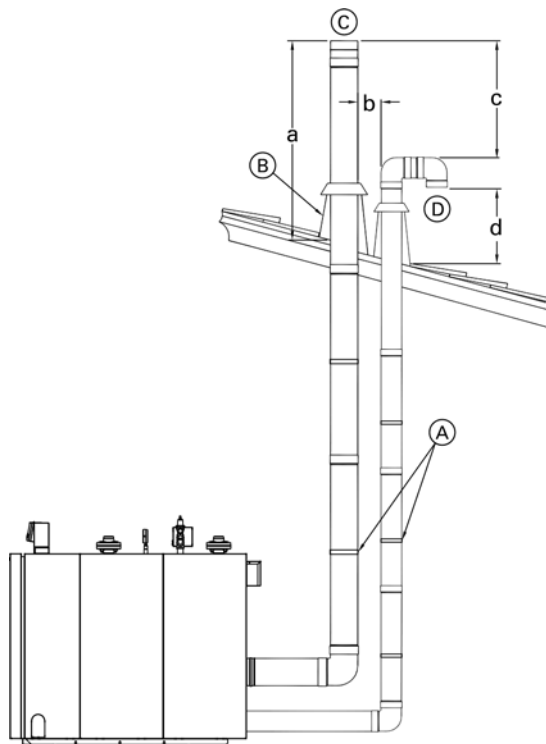

Vertical Vent Installation Sloped Roof

IMPORTANT

All PP(s) vent termination elbows, must be secured in place as specified by manufacturer.

IMPORTANT

For PP(s) systems, all exhaust vent and air intake piping and elbows exposed outside, must be UV resistant polypropylene (supplied by the vent manufacturer).

Legend

- (A) Support system
- (B) Flashings
- (C) Exhaust with screen
- (D) Combustion air intake with screen

Dimensions

- a min. 18 in. (457 mm)/ max. 48 in. (1219 mm)
- b min. 4 in. (102 mm)
- c min. 12 in. (305 mm)
- d 6 in. (152 mm) over max. local snow level (check with your local weather office for details)

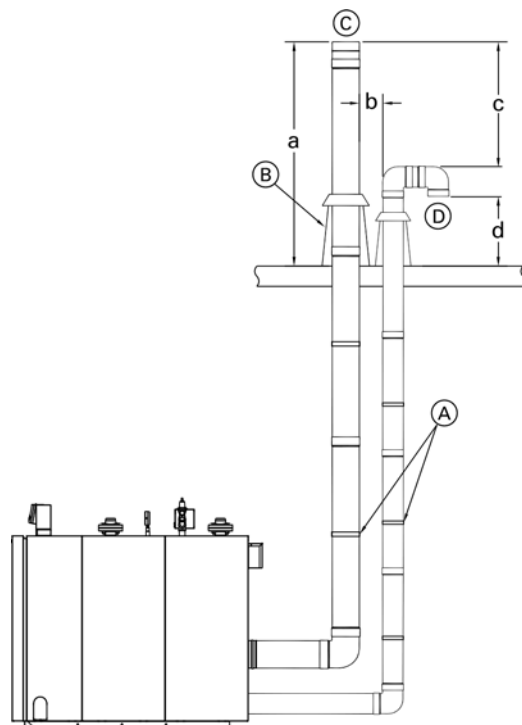

Vertical Vent Installation Flat Roof

Two Pipe System - Horizontal Exhaust / Horizontal Air Intake

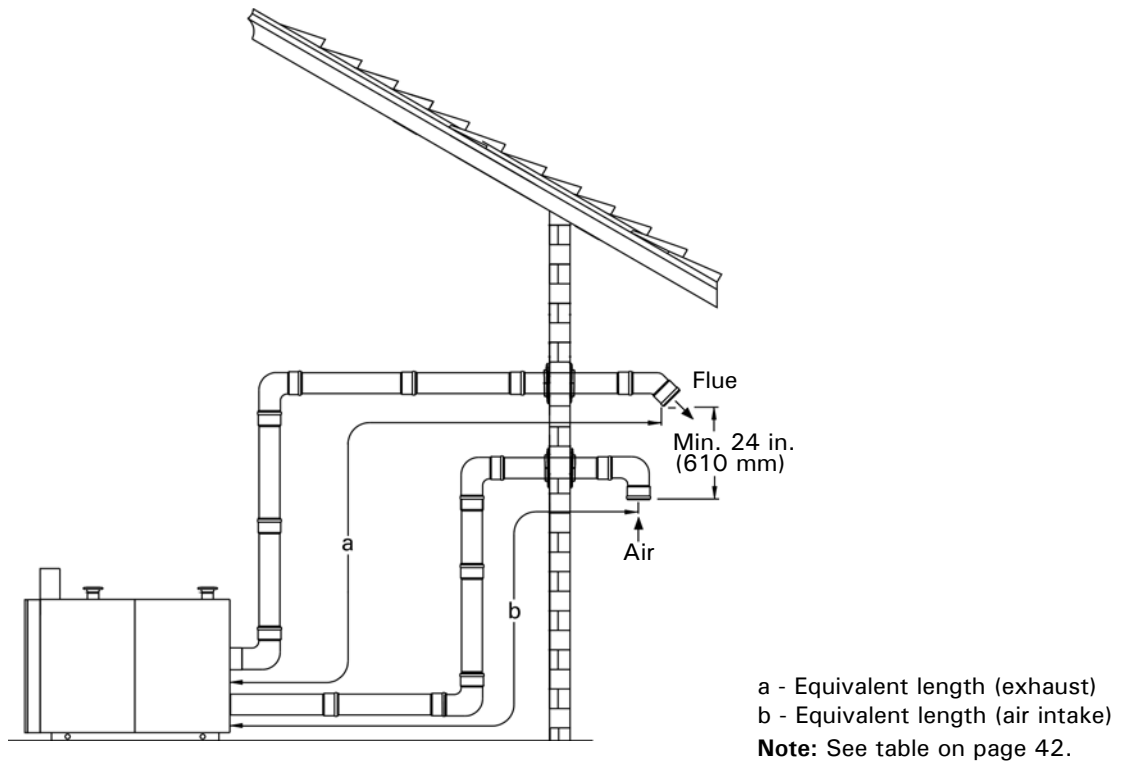

Two Pipe System - Vertical Exhaust / Horizontal Air Intake

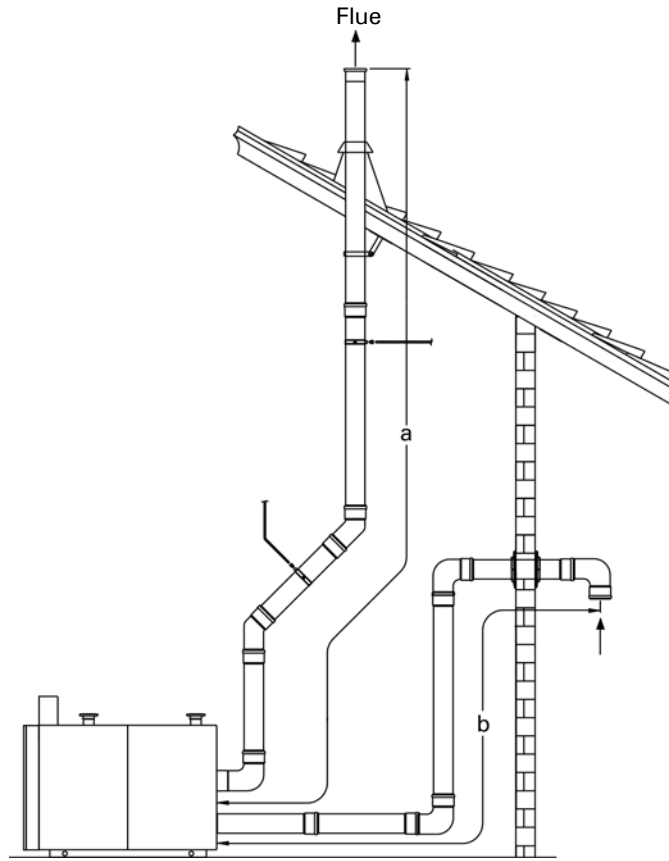

a - Equivalent length (exhaust)
 b - Equivalent length (air intake)
Note: See table below.

Two Pipe System - Vertical / Horizontal Installations

Maximum allowable equivalent length - Stainless steel / PP

Boiler Models CM2-186, -246, -311							
Flue gas	in. (mm)	8 (200)	8 (200)	10 (250)	10 (250)	12 (300)	12 (300)
combustion air	in. (mm)	6 (150)	8 (200)	6 (150)	10 (250)	6 (150)	12 (300)
Max. equivalent length a + b [ft. (m)]		200 (60)	Contact Viessmann for vent length calculation				

Note: If flexible vent or air-intake pipe are used, the total max. equivalent length will be reduced by 25% [150 ft. (45 m)]

Single Pipe System - Vertical Exhaust / Room Air Dependant

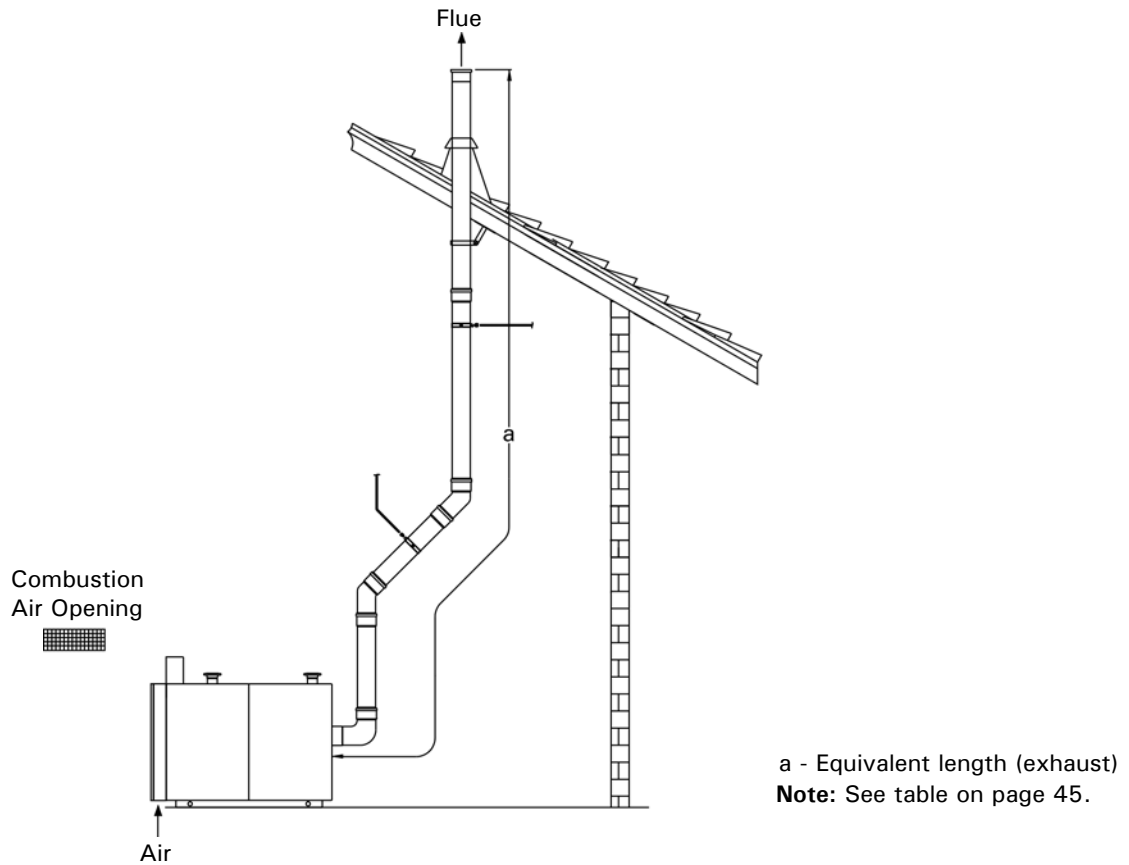

Single Pipe System - Horizontal Exhaust / Room Air Dependant

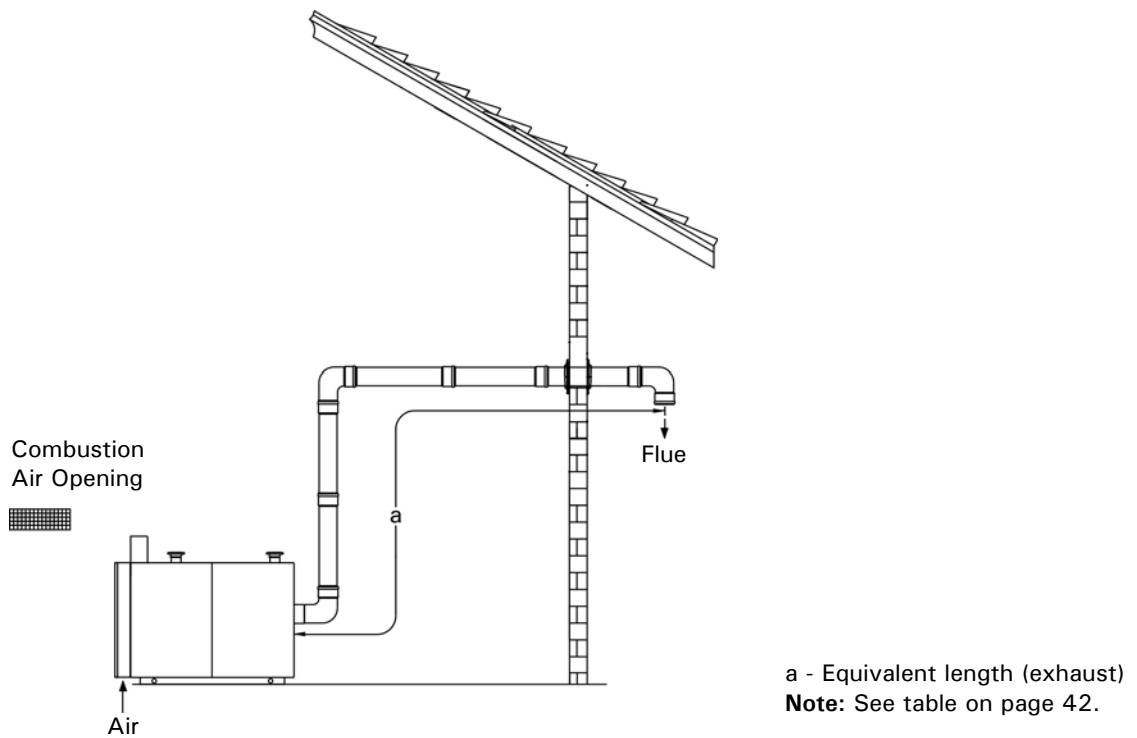

Single Pipe System - Vertical / Horizontal Installations

Maximum allowable equivalent length - Stainless steel / PP

Boiler Models CM2-186, -246, -311				
Flue gas	in. (mm)	8 (200)	10 (250)	12 (305)
combustion air	in. (mm)	6 (150)	10 (250)	12 (305)
Max. equivalent length a + b [ft. (m)]		200 (60)	Contact Viessmann for vent length calculation	

Note: If flexible vent or air-intake pipe are used, the total max. equivalent length will be reduced by 25% [150 ft. (45 m)].

Multiple Boiler Installations

Horizontal vent termination

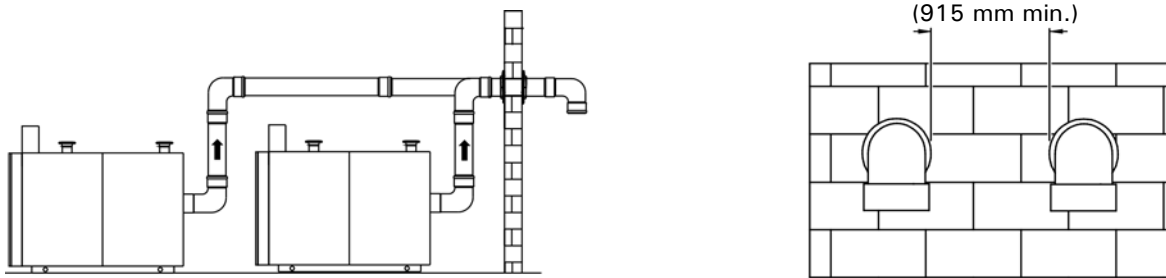

Note: 36 in. (915 mm) minimum distance apart for vent terminations.

Vertical vent termination

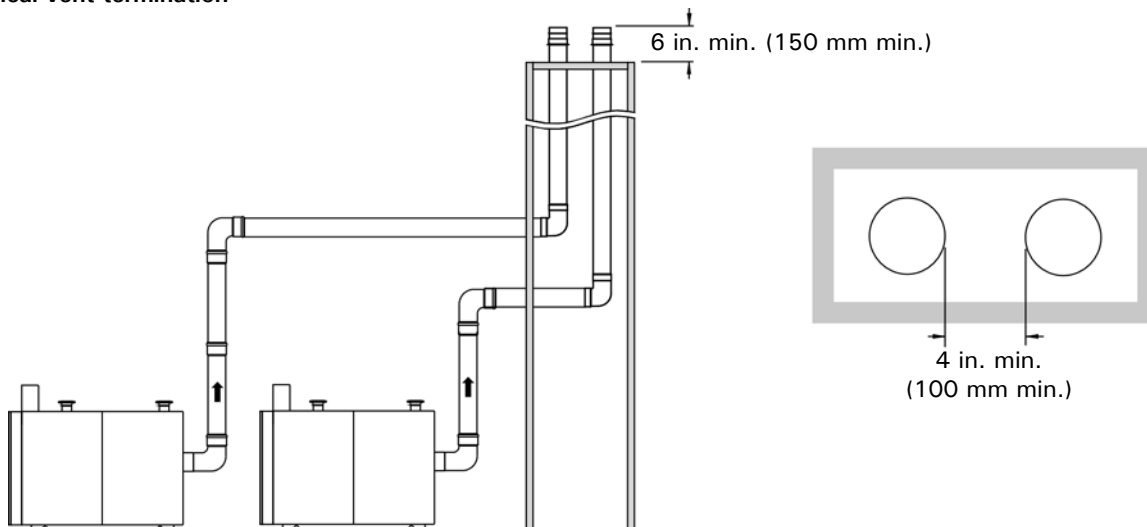

Two Pipe System - Vertical Exhaust / Vertical Air Intake

The vent diameter of CM2 boilers can be reduced to 6" (150 mm) nominal vent size. See the following table for max. vent length applicable to vent reduction diameter.

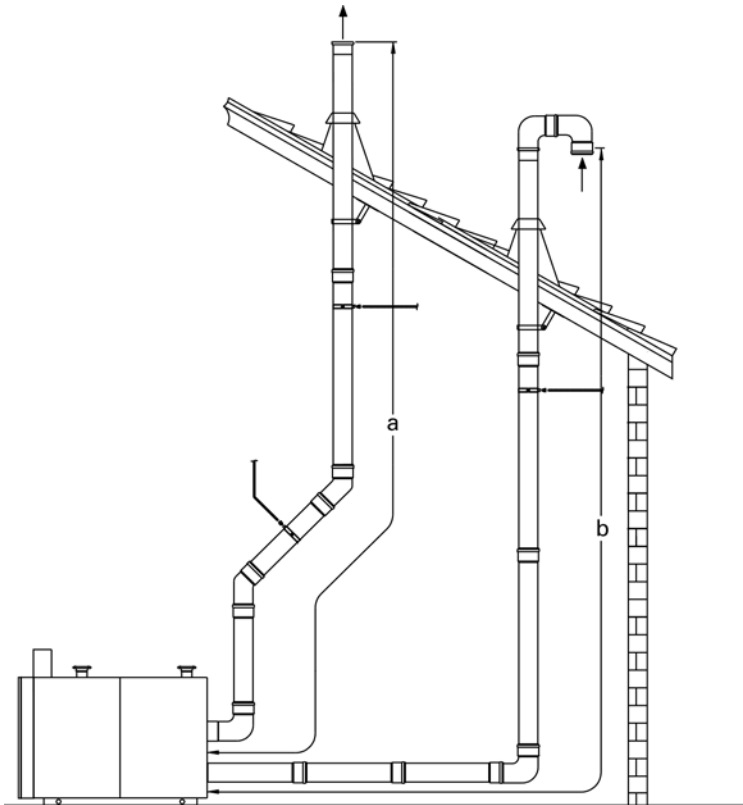

a - Equivalent length (exhaust)
b - Equivalent length (air intake)

Model	Reduced Flue vent \varnothing to	Air-intake pipe \varnothing	Max. Flue vent length "a"	Max. Air-intake pipe length "b"	Input derate %
CM2-186	6" (150 mm)	6" (150 mm)	85 ft. (26 m)	65 ft. (20 m)	0
CM2-246	6" (150 mm)	6" (150 mm)	Can not be reduced (See tables on page 42, 44)		
CM2-311	6" (150 mm)	6" (150 mm)			

Two Pipe System - Horizontal Exhaust / Horizontal Air Intake

The vent diameter of CM2 boilers can be reduced to 6" (150 mm) nominal vent size. See the following table for max. vent length applicable to vent reduction diameter.

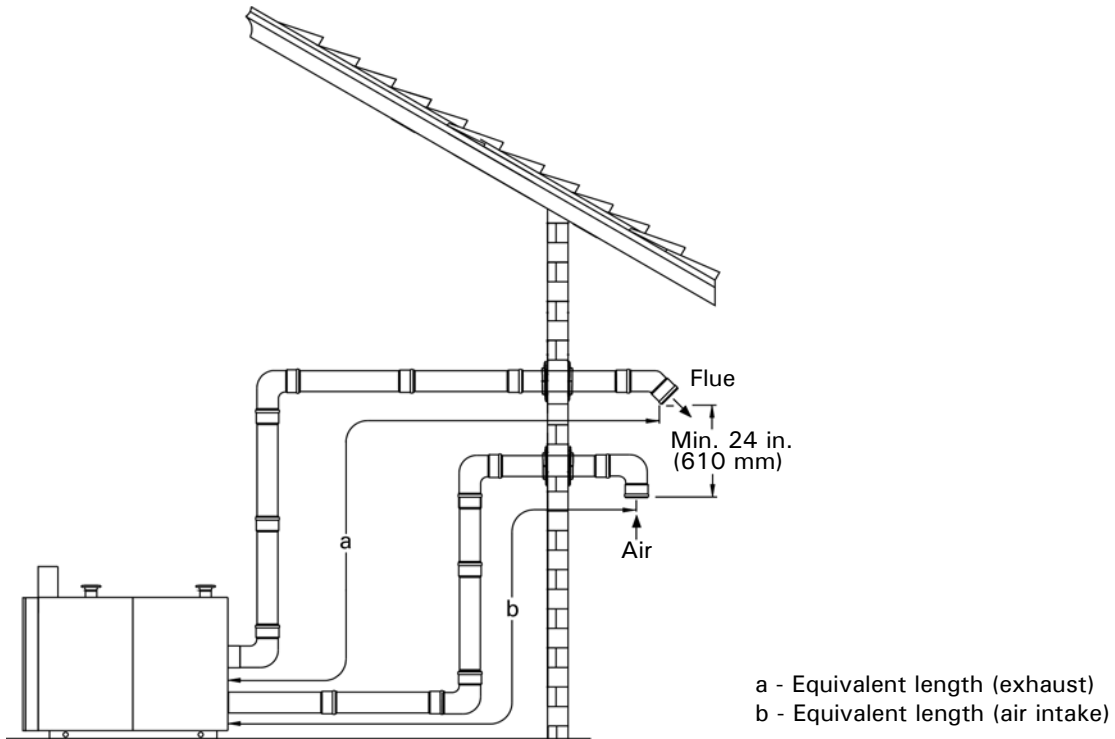

Model	Reduced Flue vent \varnothing to	Air-intake pipe \varnothing	Max. Flue vent length "a"	Max. Air-intake pipe length "b"	Input derate %
CM2-186	6" (150 mm)	6" (150 mm)	65 ft. (20 m)	56 ft. (17 m)	0
CM2-246	6" (150 mm)	6" (150 mm)	Can not be reduced (See tables on page 42, 44)		
CM2-311	6" (150 mm)	6" (150 mm)			

Two Pipe System - Vertical Exhaust / Horizontal Air Intake

The vent diameter of CM2 boilers can be reduced to 6" (150 mm) nominal vent size. See the following table for max. vent length applicable to vent reduction diameter.

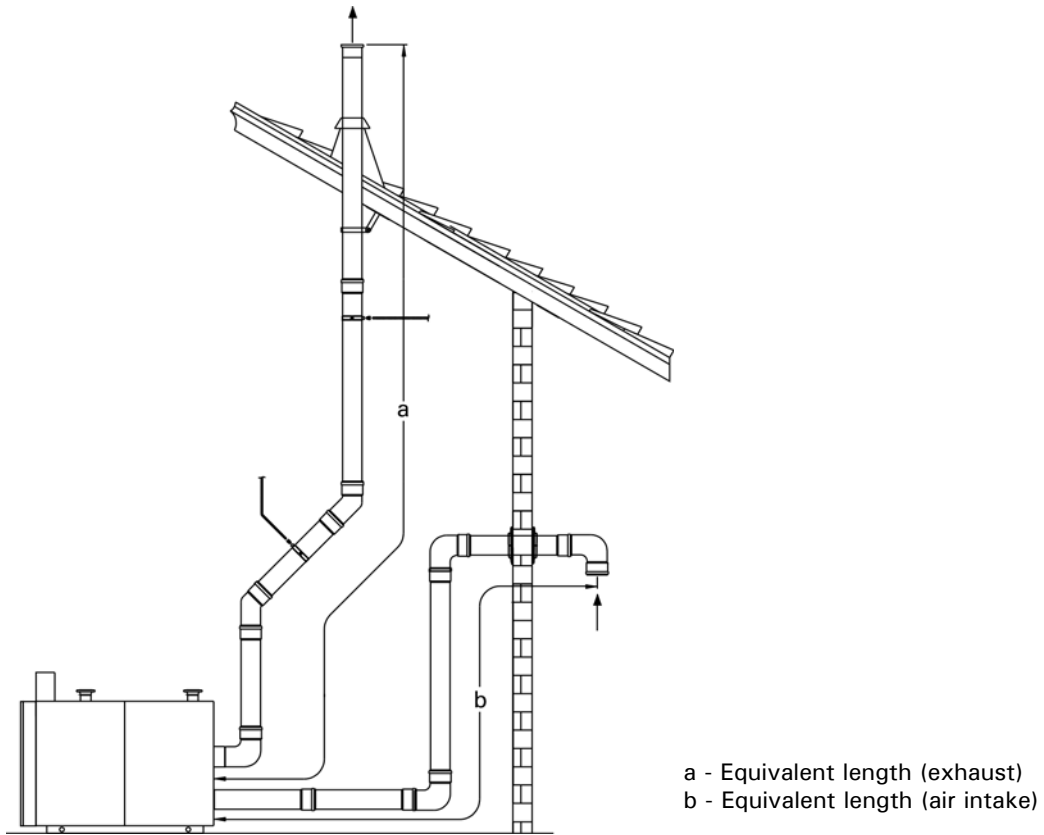

Model	Reduced Flue vent \varnothing to	Air-intake pipe \varnothing	Max. Flue vent length "a"	Max. Air-intake pipe length "b"	Input derate %
CM2-186	6" (150 mm)	6" (150 mm)	100 ft. (30 m)	100 ft. (30 m)	0
CM2-246	6" (150 mm)	6" (150 mm)	Can not be reduced (See tables on page 42, 44)		
CM2-311	6" (150 mm)	6" (150 mm)			

Single Pipe System - Vertical Exhaust / Room Air Dependant

The vent diameter of CM2 boilers can be reduced to 6" (150 mm) nominal vent size. See the following table for max. vent length applicable to vent reduction diameter.

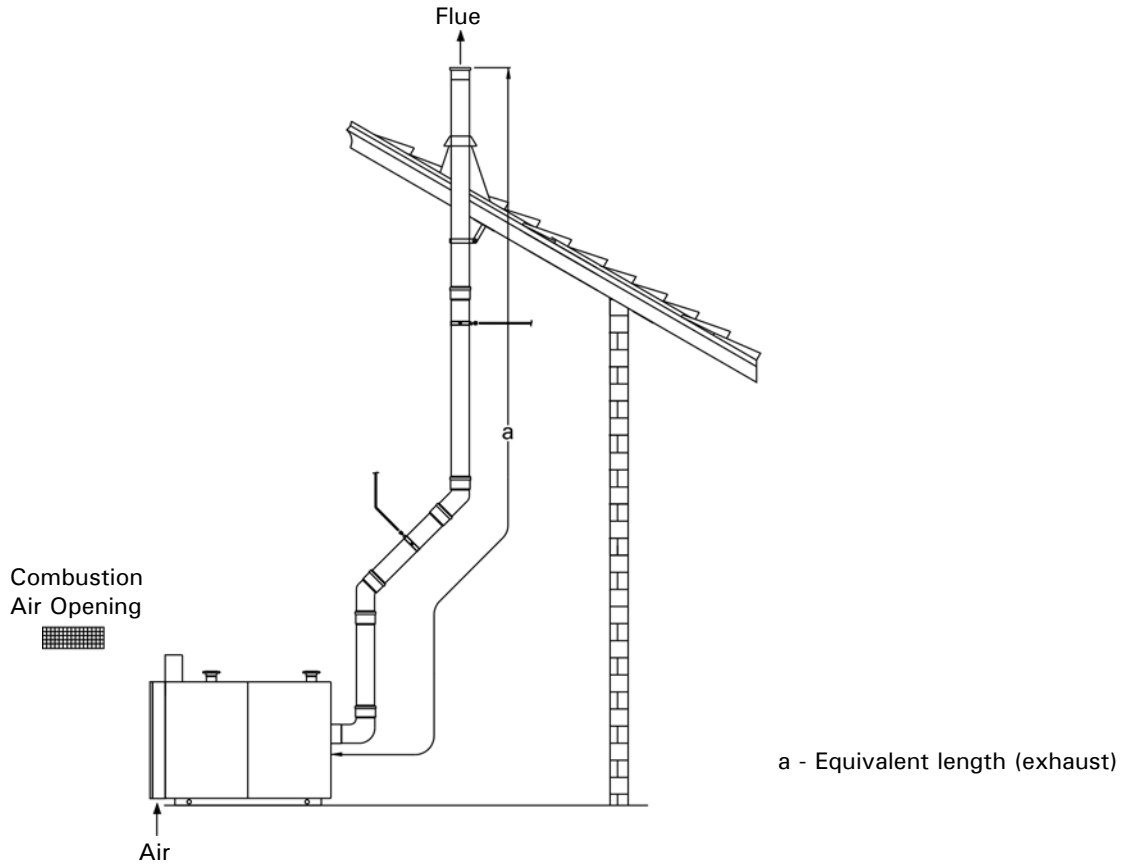

a - Equivalent length (exhaust)

Model	Reduced Flue vent \varnothing to	Air-intake pipe \varnothing	Max. Flue vent length "a"	Input derate %
CM2-186	6" (150 mm)	N/A	200 ft. (60 m)	0
CM2-246	6" (150 mm)	N/A	33 ft. (10 m)	10
CM2-311	6" (150 mm)	N/A	36 ft. (11 m)	0

Single Pipe System - Horizontal Exhaust / Room Air Dependant

The vent diameter of CM2 boilers can be reduced to 6" (150 mm) nominal vent size. See the following table for max. vent length applicable to vent reduction diameter.

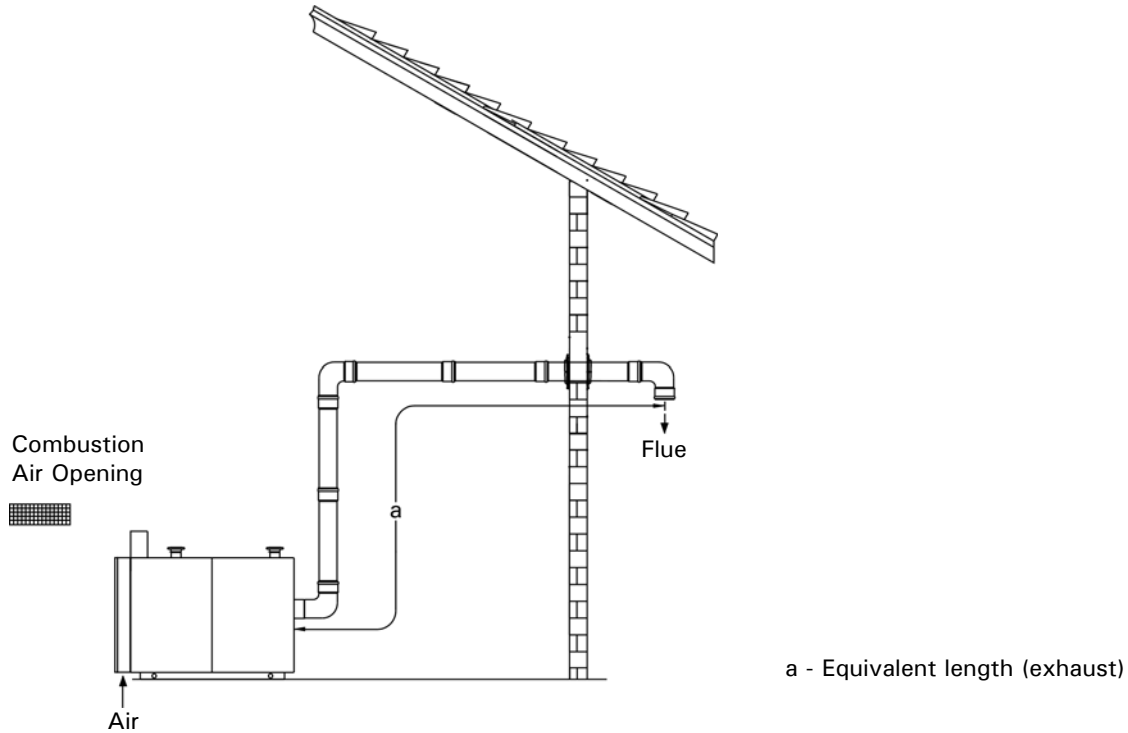

Model	Reduced Flue vent \varnothing to	Air-intake pipe \varnothing	Max. Flue vent length "a"	Input derate %
CM2-186	6" (150 mm)	N/A	154 ft. (47 m)	0
CM2-246	6" (150 mm)	N/A	Can not be reduced (See tables on page 42, 44)	
CM2-311	6" (150 mm)	N/A	30 ft. (9 m)	0

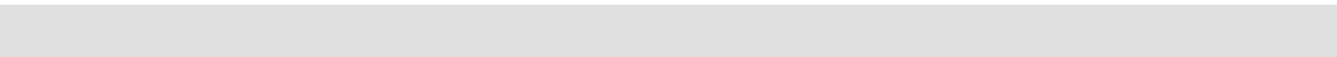

Printed on environmentally friendly
(recycled and recyclable) paper.



Technical information subject to change without notice.

Viessmann Manufacturing Company Inc.
750 McMurray Road
Waterloo, Ontario • N2V 2G5 • Canada
TechInfo Line 1-888-484-8643
1-800-387-7373 • Fax (519) 885-0887
www.viessmann.ca • info@viessmann.ca

Viessmann Manufacturing Company (U.S.) Inc.
45 Access Road
Warwick, Rhode Island • 02886 • USA
TechInfo Line 1-888-484-8643
1-800-288-0667 • Fax (401) 732-0590
www.viessmann-us.com • info@viessmann-us.com