



RVNB-NL SERIES NO LEAD BRASS RELIEF VALVES

Specification:

- Threads conform to ANSI/ASME B1.20.1
- Operating Temperature: 0-160°F (5-71°C)

Certification:

- NSF/ANSI Standard 372 Certified

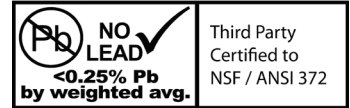

MATERIAL LIST	
Description	Materials
Body	No Lead Brass
Cap	Fibre H
Plug	No Lead Brass
Spring	304 Stainless Steel
Disc	No Lead Brass
Seat	Buna-N Rubber
Screw	Steel
Packing	No Lead Brass

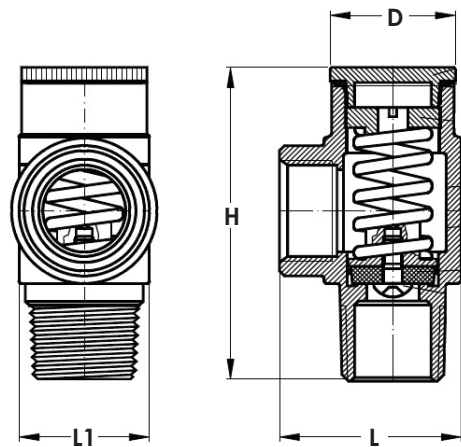

DIMENSIONS												
Part No.	Description		Factory Pre-Set	H		L		D		L1		Weight
	Inlet	Outlet		PSI	inches	mm	inches	mm	inches	mm	inches	
RVNB05-075NL	1/2" MPT	1/2" FPT	75	2.45	62.20	1.44	36.50	0.98	25.00	1.02	26.00	149
RVNB05-100NL	1/2" MPT	1/2" FPT	100	2.45	62.20	1.44	36.50	0.98	25.00	1.02	26.00	149
RVNB07-075NL	3/4" MPT	1/2" FPT	75	2.45	62.20	1.44	36.50	0.98	25.00	1.02	26.00	162
RVNB07-100NL	3/4" MPT	1/2" FPT	100	2.45	62.20	1.44	36.50	0.98	25.00	1.02	26.00	162

Pressure relief valves are recommended for all cold water system installations to protect against damage to piping and pressure tanks. Valves will be sold at factory pre-set PSI only. Accuracy +/- 15% of factory pre-set PSI. While field adjustments are not recommended the approximate operating range has been provided by the manufacturer. Any changes made to the pre-set pressure is entirely at the risk of the person/company who makes the adjustment. Any changes made should be thoroughly tested for accuracy at the time of installation. Neither the manufacturer or Boshart Industries will assume liability or responsibility caused as a result of adjusting the relief valve setting. If the pressure setting is adjusted, it will void any warranty or return of the product. Relief valves must be installed so that they drain to a floor drain, sump or other safe location with an air brake. If an outlet pipe is used then it must be at least the same diameter as the relief valve outlet.

For cold water use only. These valves are not T & P valves that are required with water heaters.



25 Whaley Avenue, PO Box 310, Milverton, ON CANADA N0K 1M0
Tel: 519-595-4444 Fax: 519-595-4380 Toll Free: 800-561-3164

www.boshart.com