

For Hydronic Heating Applications

Job Name _____

Contractor _____

Job Location _____

Approval _____

Engineer _____

Contractor's P.O. No. _____

Approval _____

Representative _____

Series DuoVent

High Capacity Air Vents with Manual Vent Feature

Sizes: 1/8" (3mm)

Series DuoVent high capacity air vents with manual vent feature provide automatic air venting for hot or cold water distribution systems. The manual vent feature provides tremendous air elimination capability for lightening fast venting of residential and commercial systems.

The DuoVent valve utilizes a float to actuate the valve plug which is located at the top of the valve. Once the air is displaced and the system pressure is sustained, the valve plug seals and prevents any water from escaping from the system.

The float vent can also operate as an anti-vacuum device since it will permit air to enter the system when it must be drained.

Features

- Body and cover are brass construction
- Air vent with silicone rubber seal
- Impurities do not usually affect function as maximum float line of water is always lower than the valve seal
- Float is high temperature resistant polyethylene
- Suitable for use with glycol systems

Specifications

Air vent shall have brass body, cover and silicone rubber seal. Float shall be constructed of high temperature resistant polyethylene and shall be for use with glycol systems. Air vent shall be Watts Series DuoVent.

Pressure – Temperature

Minimum working pressure: 1.45psi (10 kPa)

Maximum working pressure: 150psi (10 bar)

Temperature Range: 33°F – 240°F (5°C – 116°C)

Maintenance

The DuoVent can be disassembled for inspection or cleaning.

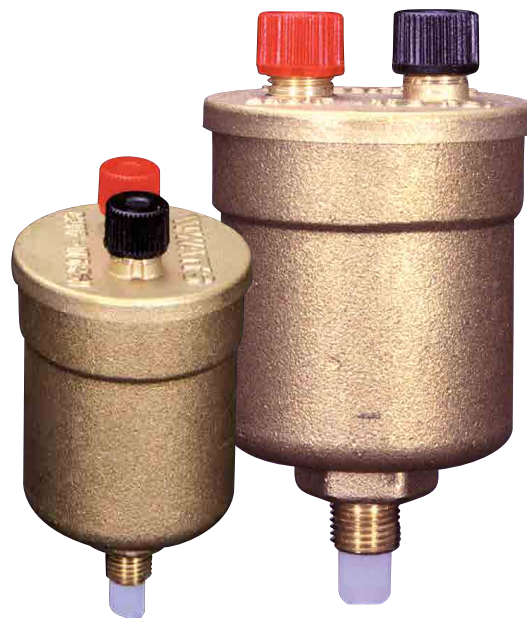

DuoVent

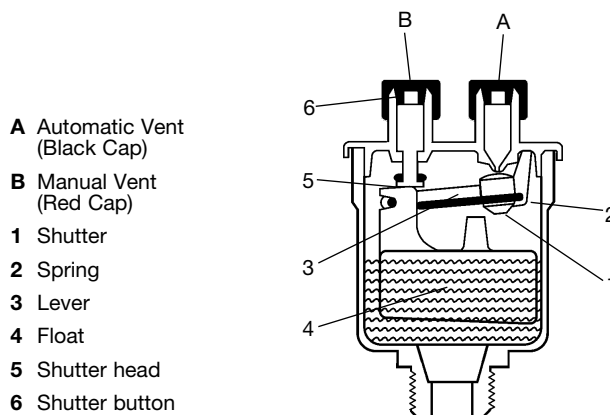

Installation – DuoVent

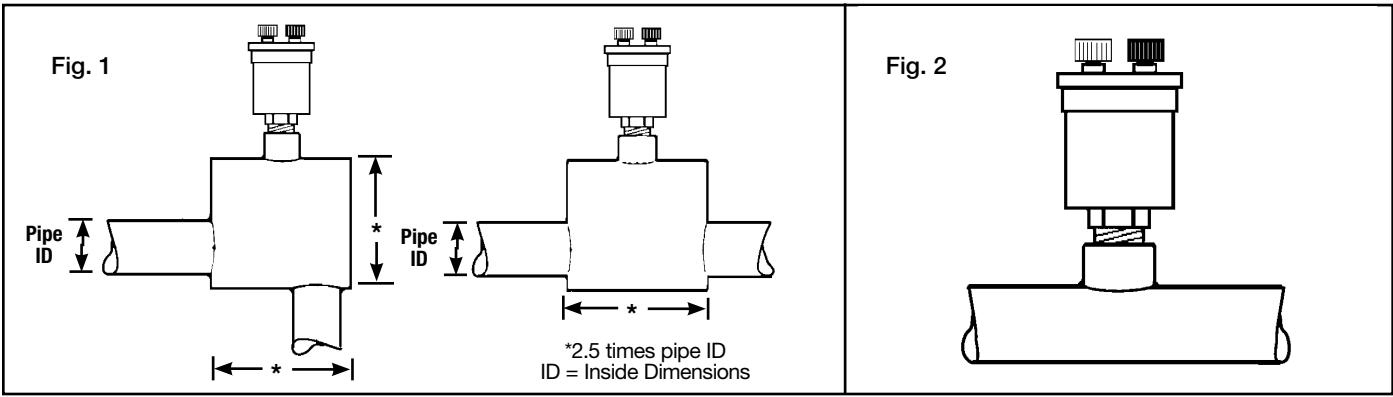

Figure 1 shows the installation of the DuoVent for the venting of air while the fluid is circulating in the system. The figure shows the required increase in pipe size in order to obtain proper separation of air from water. Watts Series AS Air Scoop which is designed for efficient separation of air from water in hydronic heating systems can also be installed.

Figure 2 – When the DuoVent is installed as shown, the air will not be vented while the fluid is circulating in the system, but it can vent when the system is shut off.

The DuoVent should be mounted only in a vertical position as its operation is based on the vertical movement of the float (see Fig. 3).

NOTICE In order to get the best results in venting air from risers, use connecting pipes of at least ½” diameter between the “Float Vent” valves and the installation.

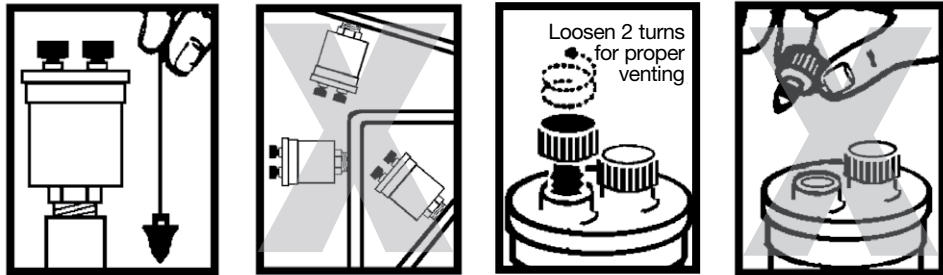

Fig. 3

Fig. 4

Operation: IMPORTANT!

After installing the DuoVent, back off the black vent cap two turns (see Fig. 4). This is the proper operating setting which will allow air to be vented from the system. It is advisable to leave the cap on to prevent impurities from entering the valve.

WARNING System fluid may be hot. Use Caution when manual venting hot water systems.

Dimensions – Weights

SIZE (DN)		DIMENSIONS						WEIGHT	
in.	mm	A	B	C	D	D1	oz.	gm.	
1/8	3	1 5/16	33	2 1/16	68	5/16	8	4.2	119

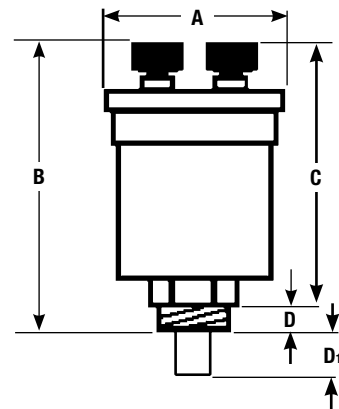

A Watts Water Technologies Company

USA: Tel: (978) 689-6066 • Fax: (978) 975-8350 • Watts.com

Canada: Tel: (905) 332-4090 • Fax: (905) 332-7068 • Watts.ca

Latin America: Tel: (52) 81-1001-8600 • Fax: (52) 81-8000-7091 • Watts.com